

MINI PRINTER

SE 7300

PANEL TYPE

SE7300 SD

SE7300 PD

SE7300 ST

SE7300 PT



CONTENTS

1. OUTLINE

- 1-1. FEATURE
- 1-2. APPLICATION

2. OPERATION

- 2-1. SPECIFICATION
- 2-2. EXPLANATION OF EACH OTHER
- 2-3. SELF-TEST
- 2-4. DUMP MODE

3. CONNECTIONS

- 3-1. SERIAL INTERFACE
- 3-2. PARRALL INTERFACE
- 3-3 THE OTHERS

4. OUTER APPEARANCE

- 4-1. SE7300

1. OUTLINE

These printers are thermal method can be equipped in rack and stand alone on desk. for various data communication, POS terminal and various system.

Prior to actual use, please read this instruction manual carefully for your correct understanding.

1-1. Feature

- Ultra small-sized rack mounting thermal printing
- Extremely light weight
- High speed printing
- Paper end detecting and auto loading
- A little noise in printing
- No ribbon type
- Confirming to RS 232c and TTL and Parallel interface.
- 24 and 32, 42 columns are available.
- Self-test and Hex decimal (dump mode) applied
- Graphic printing and bar code function are available.

1-2. APPLICATION

- Instruments and inspection system
- INDICATOR and scale
- F. A. system
- A receipt
- POS SYSTEM
- Parking system
- Various data recording

2. OPERATION

2-1. SPECIFICATION

ITEM	SPECIFICATION
DESIGN	PANEL TYPE
PRINT METHOD	DOT Matrix MACHANISM
COLUMNS	24/30/40 ON ENGLISH
FONT SIZE	40COL ENGLISH: 6x12, KOREAN: 12x12 24/30COL ENGLISH: 8x14, KOREAN: 16x14
Cartridge Ribbon	ERC-09 ,ERC-22
TOTAL DOTS	240 dots/line
PRINT SPEED	1.6 Lines/Sec
PRINT PAPER	57mmx50mm ROLL PAPER
PRINT WIDTH	48.0mm
DATA BUFFER	8Kbyte
INTERFACE	RS-232C SERIAL (BAUDRATE : 2400/9600/19200/115200bps selector) CENTRONICS PARALLEL
INPUT POWER	DC +12 ~ 24V, (1.5A ~2.0A) (OPTION : External AC Adaptor 110V/220V)
SIZE (mm)	119Wx89Dx130H

2-2. EXPLANATION EACH OTHER

● FUNCTION OF SE7300

ITEM	FUNCTION
RED LED	POWER INDICATOR. POWER ON, WHEN LIGHTING LAMP.
GREEN LED	INDICATOR "ON-LINE" <ul style="list-style-type: none"> ● ON LINE (STANDBY PRINTING.) ● LAMP OFF(NOT TO PRINT). ● LED FLASHING, WHEN NO PAPER
FEED S/W	PRESS TO ADVANCE PAPER

2-3. SELF TEST

The self -test mode checks the printers control circuit function, setting parameter, software version, and printer quality.

- ① Before running the self -test, make sure there is sufficient paper.
- ② On pressing FEED S/W(SE7300) , and power ON, starting the self-test.
- ③ Printer becomes ready to receive data from the host.

2-5. DUMP MODE

Dump mode checks whether printer receives data correctly from the host or not.

- ① Before running the self -test, make sure there is sufficient paper.
- ② On pressing FEED S/W(SE7300), and power ON, starting the self-test.
- ③ After ending the self-test, continually press FEED S/W (SE7300), Then print "***[HEX DUMP PRINT START]**" after 2 seconds.
- ④ Thought you don't touch any s/w, the printer take out HEXA mode changed data from host
- ⑤ If power off, printer "s recovered to normal mode

3. CONNECTIONS

3-1. Serial interface

1) Serial(RS-232C)

Data Transmission	RS-232C Asynchronous
Handshaking	DTR/DSR or XON/XOFF control
Signal Level	MARK = -3 ~ -15V : "1" SPACE = +3 ~ +15V : "0"
Baud Rate	9600/19200bps (Default : 9600bps)
Bit Length	8 bits
Parity	None
Stop Bits	1 Stop
Connector	D-SUB 25 FEMALE

2) Interface Connection

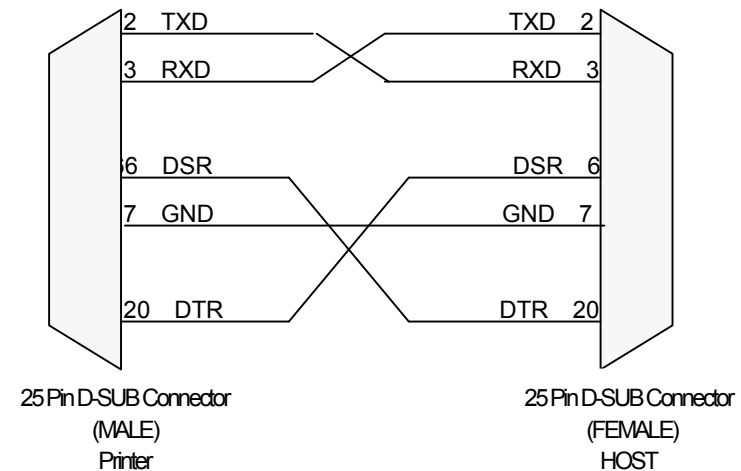

- Handshaking 01 XON/XOFF 시 DSR/DTR Line is not available.
- On no paper , 0x07 has send on 2 times 2, and 0x11(XON) has send on refreshing paper.

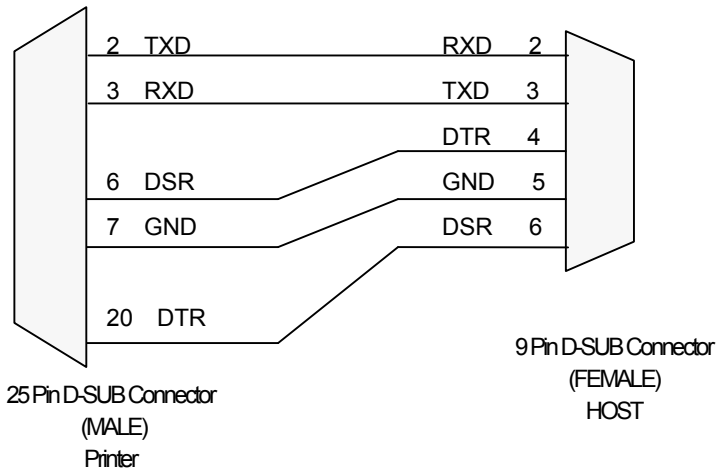

3) Interface Connector

Pin	SIG.	DIRCTION	FUNCTION
2	TXD	OUT	Transmitter data
3	RXD	IN	Receive data
6	DSR	IN	<ul style="list-style-type: none"> ● Indicate Whether host could receive data or not . ● Can do it on SPACE , not do it on MARK ● Can operating on DSR/DTR Handshaking, printer transmitter data after checking the signal. ● Use it on Hardware Handshaking.
7	GND	-	Signal Ground
20	DTR	OUT	<ul style="list-style-type: none"> ● Indicate Whether printer could receive data or not. ● Can do it on SPACE , not do it on MARK, when setting DTR/DSR control ● It's on MARK as bellows; <ul style="list-style-type: none"> - Full buffer in printer - Operating on error - On self-test

3-2.Parallel interface

1) Parallel

Data Transmission	8-bit parallel
Handshaking	STROBE and BUSY or ACK
Connector	D-SUB 25 MALE

2) Interface Connection

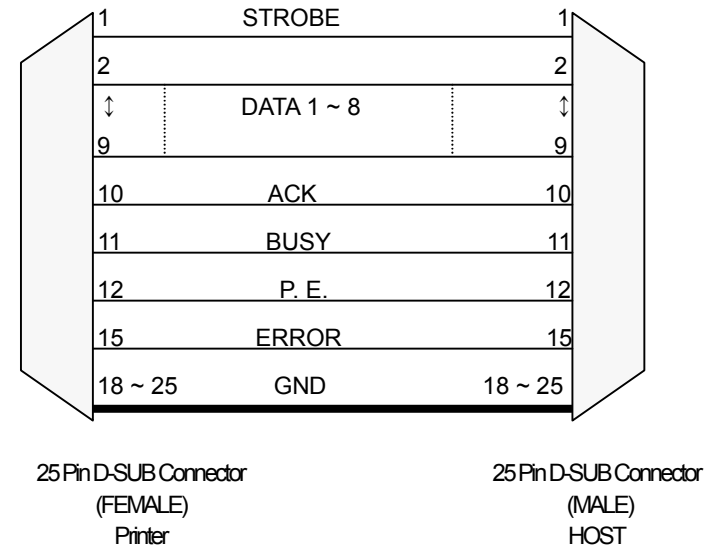

3) Interface Connector and function

No	SIGNAL	DIR.	FUNCTION
1	/STROBE	IN	<ul style="list-style-type: none"> ● STROBE Pulse is occurred on reading data. ● HIGH on normal , LOW on reading data
2	DATA0	IN	<ul style="list-style-type: none"> ● Parallel data bits ● "1"on HIGH, "0"on LOW.
3	DATA1	IN	
4	DATA2	IN	
5	DATA3	IN	
6	DATA4	IN	
7	DATA5	IN	
8	DATA6	IN	
9	DATA7	IN	
10	ACK	OUT	<ul style="list-style-type: none"> ● Ready signal to receive data. ● HIGH on normal , LOW on operatong.
11	BUSY	OUT	<ul style="list-style-type: none"> ● Indicate Whether printer could receive data or not. ● Can not receive on HIGH, can do it on LOW
12	PE	OUT	<ul style="list-style-type: none"> ● Paper is or not ● No paper on HIGH, set it on LOW.
13	SLCT	OUT	● Whether printer is ON-LINE or not . (NC)
14	/AUTO FD	IN	● 1Line space is advanced on auto-feed. (NC)
15	/ERROR	OUT	● Checking printer " ERROR"
16	/INIT	IN	● Hardware Reset in printer.(NC)
17	SLCT IN	IN	● Select printer on LOW. (NC)
18~25	GND	-	Signal Ground

4) Signal Timing Chart

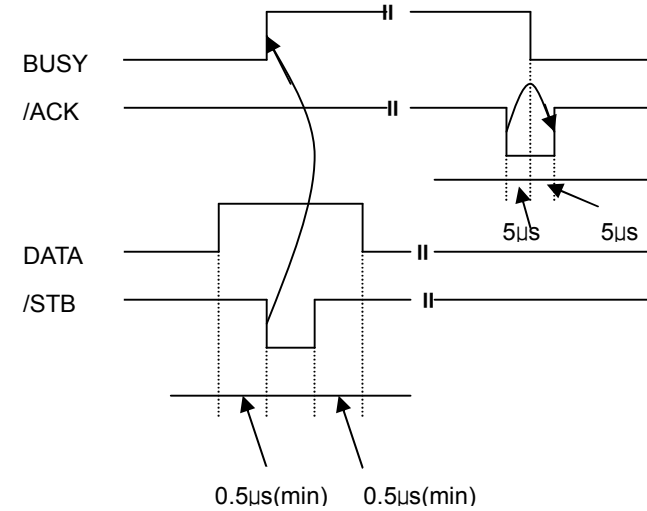

3-3. THE OTHERS

1) SW CONNECTOR

- SE7300

SW No.		Define
1	2	Serial Baud Rate
OFF	OFF	9600 bps
ON	OFF	192000bps
OFF	ON	115200bps
ON	ON	2400bps
3	HanGul Type	
OFF	WANSUNG	
ON	JOHAP	
4	Control Command	
ON	EPSON	
OFF	INTERNAL	
5	6	Columns
OFF	OFF	30Columns
ON	OFF	40Columns
OFF	ON	24Columns
ON	ON	24Columns
7	8	Parity
OFF	OFF	None Parity
ON	OFF	Odd Parity
ON	ON	Even Parity

* Default mode on factory - out

2) POWER CONNECTOR

	CONNECTOR
+	DC +12V or 24V 1.5A
G	GND

4. OUTER APPARANCE

4-1. SE7300

