

# SI540

## Digital indicator

### User manual

Manual Ver 3.10

Program Ver 3.10



## Contents

<b>1. Precautions</b> .....	<b>3</b>
<b>2. Introduction</b> .....	<b>4</b>
2-1. Introduction .....	4
2-2. Features.....	4
2-3. Components.....	4
<b>3. Specification</b> .....	<b>5</b>
3-1. Specification.....	5
3-2. Front.....	6
3-3. Rear Panel.....	9
<b>4. Installation</b> .....	<b>10</b>
4-1. Size.....	10
4-2. Panel Cutting Size.....	10
4-3. How to connect Load cell to Indicator .....	11
4-4. External Equipment Connection.....	12
<b>5. Set-up</b> .....	<b>14</b>
5-1. Calibration.....	14
5-2. Simulation Calibration.....	22
5-3. Function Mode.....	30
5-4. Test mode.....	49
<b>6. Option card</b> .....	<b>53</b>
6-1. Serial interface.....	53
6-2. Ethernet Interface.....	54
6-3. Analog output .....	55
6-4. Parallel interface.....	57
6-5. Data Storage Device (SD memory card) .....	60
6-6. Option card combination.....	62
<b>7. Communication Data Format</b> .....	<b>63</b>
7-1. Stream Mode.....	63
7-2. Command mode.....	68
7-3. Command mode (compatible with SI4410).....	80
7-4. Modbus .....	90
7-5. Print format.....	94
<b>8. Error &amp; treatment</b> .....	<b>95</b>
8-1. Error during Load Cell Installation.....	95
8-2. Error during Calibration .....	96
8-3. Error and Treatment.....	97

# 1. Precautions

## 1-1. Caution / Warning Mark



This mark warns the possibility to arrive death or serious injury in case of wrongly used.

- 1) Do not drop the product and avoid serious external damage on it.
- 2) Do not install the product under direct sunshine or severe vibration.
- 3) Do not install the product under conditions with high voltage or severe electric noise.
- 4) Turn off the power when you use it with external input devices.
- 5) Do not sprinkle water on the product or avoid rainy conditions.



Caution Mark means there is possibility to cause material loss if the product was not handled in a proper way.

- 1) The products can be changed without previous notice as the version is upgraded.
- 2) As version is upgraded the product version increases and all of the function will remain if possible.
- 3) Do not use the product at conditions with fluctuating temperature or severe vibration.

## 1-2. Copyrights

- 1) All rights are reserved by SEWHACNM Co., LTD.
- 2) Any kind of copy or distribution is prohibited without permission from SEWHACNM Co., LTD.
- 3) This manual can be changed without previous notice as the version is upgraded. If you have any kind of inquiries, please contact your local agent or the Headquarter, SEWHACNM Co., LTD.

## 1-3. Inquiries

If you have any inquiries about our products, please contact us at following address.

- 1) Headquarter : SEWHACNM Co., LTD
- 2) Homepage : <http://www.sewhacnm.co.kr>
- 3) E-mail : [sales@sewhacnm.co.kr](mailto:sales@sewhacnm.co.kr)

## 2. Introduction

### 2-1. Introduction

Thank you for Purchasing “SI 540”, the digital weighing indicator. This product is a high-quality indicator with weighing control program. Plus, Current Loop for external display and RS232C Interface with Modbus Protocol are available for user’s convenience.



User can choose various options like Serial Interface (Modbus RTU), Ethernet (TCP/IP), Analog Out, BCD IN/OUT and SD Memory card.

Please learn and review this manual before use it and enjoy all of the function of this product.

### 2-2. Features

- 1) It is convenient to install this product into a control box as a panel type.
- 2) This product is resistant to dust or moisture since display part is covered with polycarbonate file.
- 3) RS232C and Current loop interface available (Modbus Protocol including)
- 4) You can choose various options as below.
  - Serial interface RS232C / RS422 / RS485
  - Ethernet interface (TCP/IP)
  - Analog Output 4~20mA, 0~10V
  - Parallel interface BCD out / BCD in
  - Data storage device (SD Memory Card)

### 2-3. Components

		
Indicator	Manual	Power cable

## 3. Specification

### 3-1. Specification

Content		Specification	
Load Cell Input Analog Signal	Display Resolution	1/20,000	
	Internal Resolution	1/2,000,000 ( $\pm 1,000,000$ )	
	Input Sensitivity	Min 0.1 $\mu$ V/V	
	Max Signal Input Voltage	Max 3.2mV/V	
	Load Cell Excitation	DC +5V	
	A/D Converting Method	Sigma-Delta	
	Decimal Point	0, 0.0, 0.00, 0.000	
	Drift	Zero	10PPM/ $^{\circ}$ C
		Span	10PPM/ $^{\circ}$ C
Non Linearity	0.005% Max		
Operating Environment	Operating Temperature Range	-10 $^{\circ}$ C ~ +40 $^{\circ}$ C [14 $^{\circ}$ F ~ 104 $^{\circ}$ F]	
	Operation Humidity Range	40% ~ 85% RH, No Condensation	
Front	Display	1. Main : 0.8 inch(20.36mm), Red/Green FND 2. Sub : 0.36 inch(9mm), Red FND 3. State(word) 16 digits, Red/Green FND	
	Key	15EA	
Interface	External Input	6EA, Dry Contact(Zero Voltage Contact)	
	Relay Out	7EA Contact rate: 250V 5A AC / 30V 3A DC	
	Serial interface	RS232C	PC, PLC, Printer, etc.
		Current Loop	External display
Power	AC : 100~240V, 50~60Hz, 0.5A		
Size	200mm(W) x 100mm(H) x 140mm(D), 1.2Kg		
Option	OP-01	Serial Interface	RS-422
	OP-02		RS-485
	OP-03		RS-232C
	OP-04	Ethernet Interface	TCP/IP
	OP-05	Analog Output	Iout (4~20mA)
	OP-06		Vout (0~10V)
	OP-07	Parallel Interface	BCD OUT
	OP-08		BCD IN(Number input)
	OP-09	Data storage device	SD memory card

### 3-2. Front

#### 3-2-1. Display and keypad

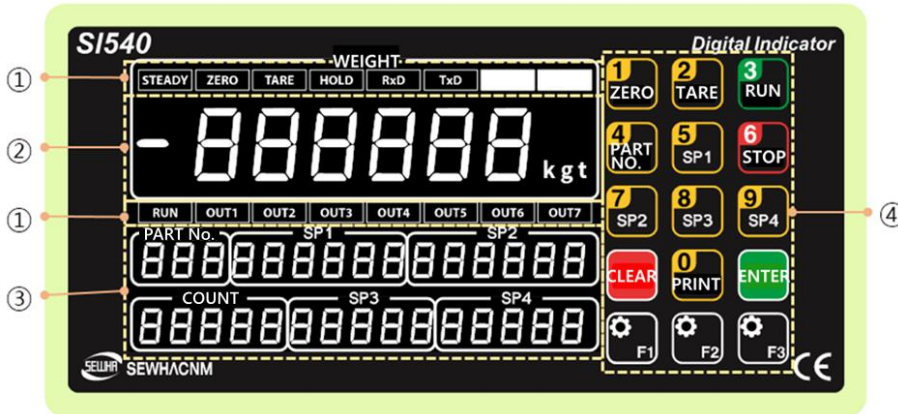

① Condition















- STEADY : Current weight is steady
- ZERO : Current weight is zero
- TARE : Using Tare function
- HOLD : Using Hold function
- RxD : Receiving data via RS232C
- TxD : Transmitting data via RS232C
- RUN : Weighing mode is running
- OUT1 : OUT1(Relay) ON
- OUT2 : OUT2(Relay) ON
- OUT3 : OUT3(Relay) ON
- OUT4 : OUT4(Relay) ON
- OUT5 : OUT5(Relay) ON
- OUT6 : OUT6(Relay) ON
- OUT7 : OUT7(Relay) ON

② Main Display : Weight, Words, Unit



























③ Sub-display : Part No., SP1, SP2, Count, SP3, SP4

④ Keypad

### 3-2-2. Key

	- Set zero point
	- Set Tare - Reset Tare
	- Run weighing mode
	- Part number setting
	- SP1 Setting
	- Stop weighing mode
	- SP2 Setting
	- SP3 Setting
	- SP4 Setting
	- Print displayed weight value (Transmit the data to printer)
	- Press 4 times within 3secs to enter Function Mode.
	- Press 4 times within 3secs to enter Hidden Function Mode.
	- Cancel or Move to Previous Step.
	- Save and Move to Next Step.

### 3-2-3. Key combination

 → 	Input Tare weight with number keys
 → 	Max Tare weight (under setting F532-0)
 → 	Min Tare weight (under setting F532-0)
 → 	Forced discharge
 → 	Under-value Setting
 → 	Over-value Setting
 → 	Print Sub-total
 → 	Delete Sub-total
 → 	Print Total of current Part number
 → 	Charge Free Fall Setting
 → 	Discharge Free Fall Setting
 → 	Delete Total of current Part number
 → 	Print Total of whole Part numbers
 → 	Delete Total of whole Part numbers

- The maximum of weighing counting number is 999,999. It will be initialized when it is over the max value.
- The maximum of cumulative weighing counting number is 999,999,999. It will be initialized when it is over the max value.



### 3-3. Rear Panel

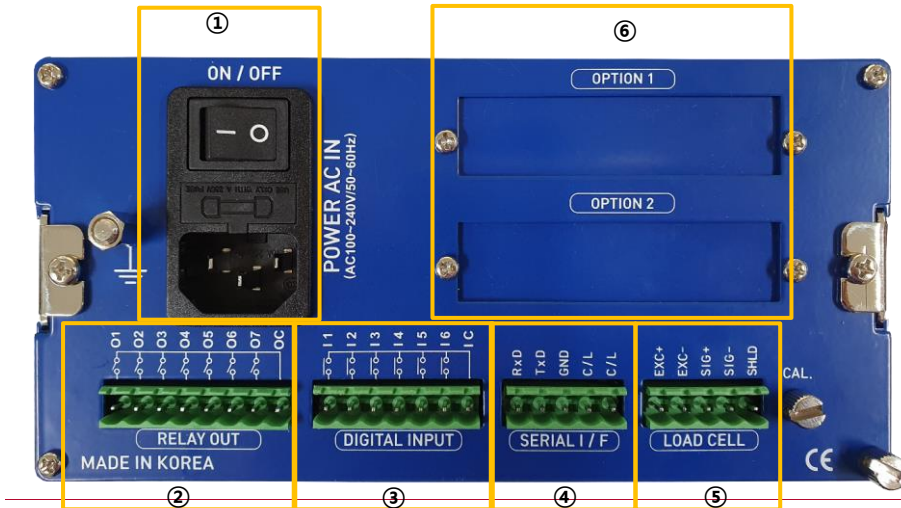

- ① AC Power Input Terminal
- ② Relay Out Terminal (F141~147)  
01~07: Relay Out 1~7 / OC: Relay Out Common Terminal
- ③ External Input Terminal (Dry Contact : zero voltage point)
- ④ Serial Interface Terminal  
RS-232C and Current loop included
- ⑤ Load Cell Terminal
- ⑥ Option port (Selectable)



Check the specification of the each terminal written on the panel when you connect the product to other devices.

## 4. Installation

### 4-1. Size (Unit: mm)

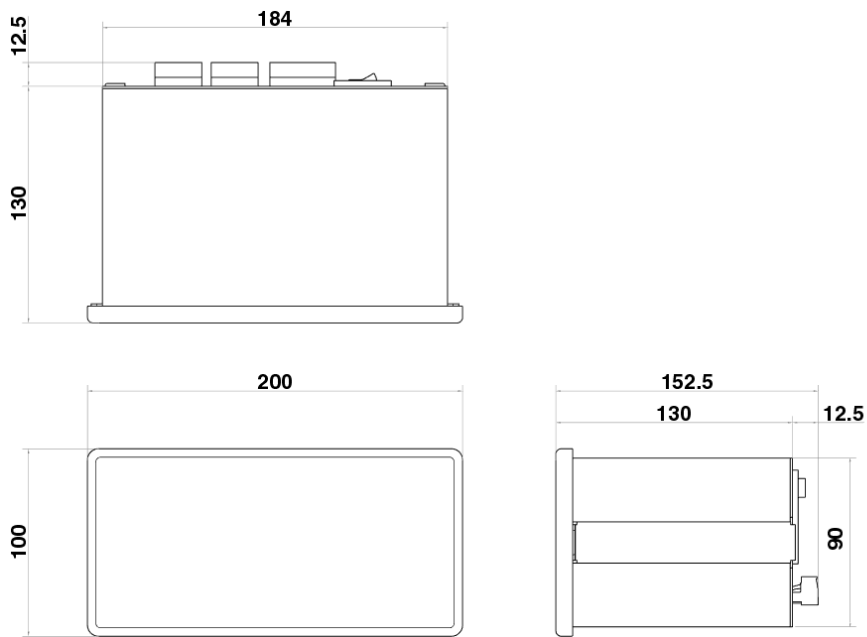

### 4-2. Panel Cutting Size (Unit: mm)

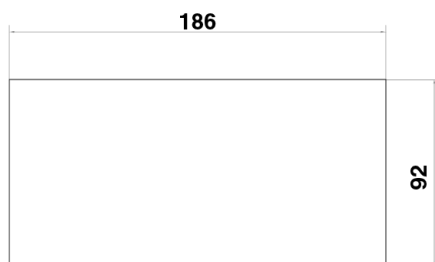

### 4-3. How to connect Load cell to Indicator

How to install load cell input terminal

(The color of the cables can differ from each manufacturer.)



1. If you use tension type of load cell as compression type, connect SIG+ and SIG- crossly.
2. The product can be damaged if you connect other cable to load cell input terminal.
3. Turn off the power of the indicator during connection to load cell.
4. Do not weld around the device.  
(Parts of internal circuit of indicator or load cell can be broken during arc welding or electric welding.)



#### ※ Precautions for Indicator-Load Cell Connection

1. You can use a maximum of 8 load cells. (350Ω standard)
2. The product has to be horizontal to the ground for more precise value.
3. Use summing box to adjust output deviation minimally when you install load cell more than two. (Each output gap can cause a margin of error.)
4. Change in temperature can cause a margin of error.
5. Do not weld around the device. If you need, disconnect every cable of indicator.
6. If you weigh static electricity, use earth shield wire or other ways to protect static electricity flowing in Indicator.

## 4-4. External Equipment Connection

### 4-4-1. Serial Interface (Basic Option) – RS232C and Current loop

- 1) RS232C interface is vulnerable to electric noise. It is mainly used for Short distance communication (within 10m approximately) like computer, PLC, External Display, and etc.

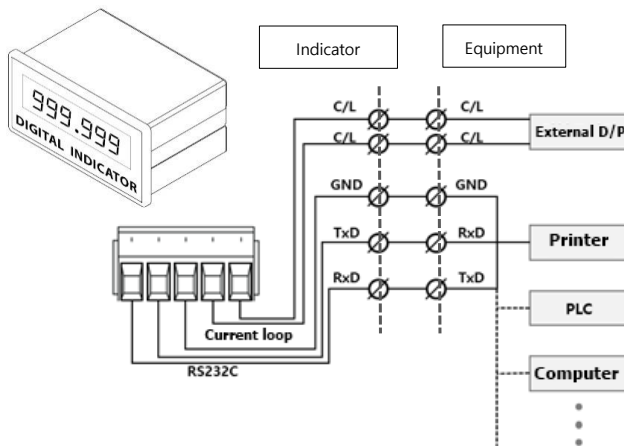

- 2) Current Loop Interface is much stronger against electric noise that RS232C Interface, so Current Loop is adequate for middle distance communication (within 100M approximately) like External display.

### 4-4-2. External Input (Basic Option) – Input 6EA

- 1) Each external digital Input can be set on F156~161.
- 2) Dry contact for Input Signal

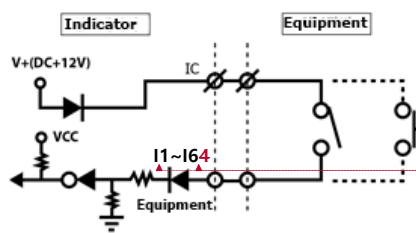

- 3) Terminal Component
  - I C : Common Input terminal (V+ : 12V DC)
  - I 1 ~ I 6 : Input signal (Zero voltage point-relay or switch signal)

서식 있음: 가운데

서식 있음: 글꼴: 9 pt, 굵게, 글꼴 색: 텍스트 1

서식 있음: 글꼴: 9 pt, 굵게, 글꼴 색: 텍스트 1

### 4-4-3. Relay Out (Basic Option) – Output 7EA

- 1) Each external digital Input can be set on F141~147.
- 2) Output is Basically A contact, you can choose and use what you want on F149~155 after setting F148-01.

3)

Contact Ratings VDC	Contact Ratings VAC
30V 3A	250V 5A

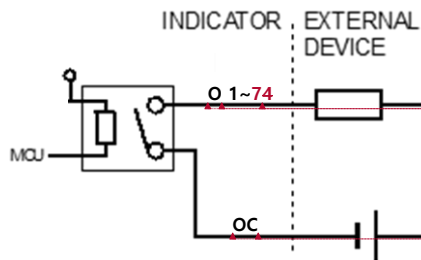

- 4) Terminal Component
  - OC : Common Output terminal
  - O1~O7 : Output signal (Output relay: zero voltage point-relay or switch signal)

- 서식 있음: 글꼴: 굵게
- 서식 있음: 글꼴: 9 pt, 굵게, 글꼴 색: 텍스트 1
- 서식 있음: 가운데
- 서식 있음: 글꼴: 9 pt, 굵게, 글꼴 색: 텍스트 1
- 서식 있음: 글꼴: 굵게
- 서식 있음: 가운데
- 서식 있음: 글꼴: 9 pt, 굵게, 글꼴 색: 텍스트 1

## 5. Set-up

### 5-1. Calibration

Calibration is a work to correct linearity from zero to Max Capacity, which becomes standard when an indicator displays the current weight.



- When enter Calibration mode, Tare/Hold/Print function is initialized.
- Preheat the Indicator for 5 minutes before Calibration to get more exact result.

#### Step 1. Enter Calibration mode

Press CAL Key



<CAL key position>

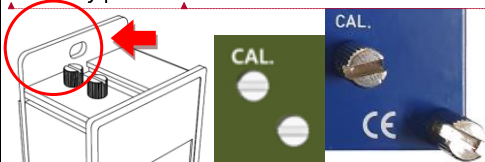

Remove "CAL-BOLT" on the Rear panel and press "CAL key" inside.

<Key Explanation>

- : Select Calibration Mode
- : Save and Move to next step
- : Cancel and Back to previous step

서식 있음: 글꼴: (영어) Noto Sans CJK KR DemiLight, (한글) Noto Sans CJK KR DemiLight, 10 pt

서식 있음: 글꼴: (영어) Noto Sans CJK KR DemiLight, (한글) Noto Sans CJK KR DemiLight, 10 pt

서식 있음: 표준, 가운데, 글머리 기호 또는 번호 없이

서식 있음: 글꼴: (영어) Noto Sans CJK KR DemiLight, (한글) Noto Sans CJK KR DemiLight, 8 pt

서식 있음: 글꼴: (영어) Noto Sans CJK KR DemiLight, (한글) Noto Sans CJK KR DemiLight, 10 pt, 굵게 없음

서식 있음: 글꼴: (영어) Noto Sans CJK KR DemiLight, (한글) Noto Sans CJK KR DemiLight, 8 pt

서식 있음: 글꼴: (영어) Noto Sans CJK KR DemiLight, (한글) Noto Sans CJK KR DemiLight, 10 pt

서식 있음: 글꼴: (영어) Noto Sans CJK KR DemiLight, (한글) Noto Sans CJK KR DemiLight, 8 pt

서식 있음: 글꼴: (영어) Noto Sans CJK KR DemiLight, (한글) Noto Sans CJK KR DemiLight, 10 pt

서식 있음: 글꼴: (영어) Noto Sans CJK KR DemiLight, (한글) Noto Sans CJK KR DemiLight, 12 pt

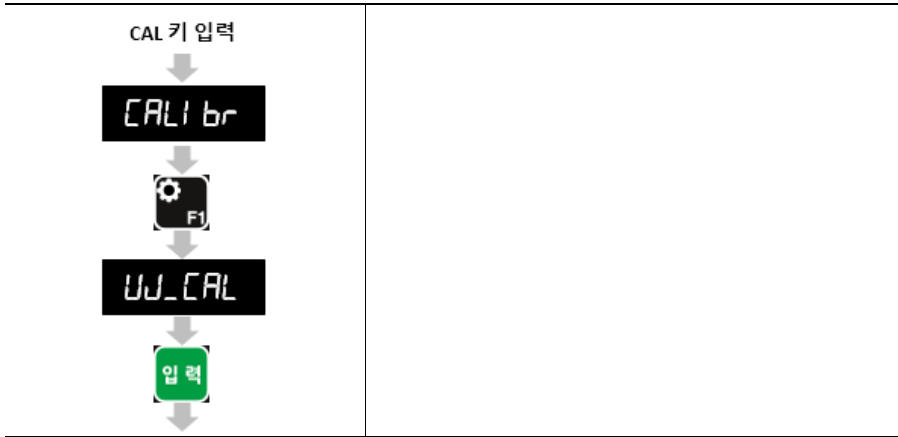

2) 인디케이터 상단에 있는 중량  
조정 봉인 볼트(앞쪽)를 제거  
하고, 내부에 있는 CAL키를  
누릅니다.

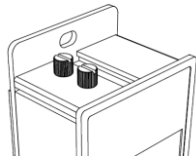

3) CAL br 가 표시되면



키를 누릅니다.

4) UJ\_CAL 가 표시되면



키를 누릅니다.

5) NET GROSS 키로 설정 취소 및 이전 단계로 복귀합니다.

### Step 2. Set Unit

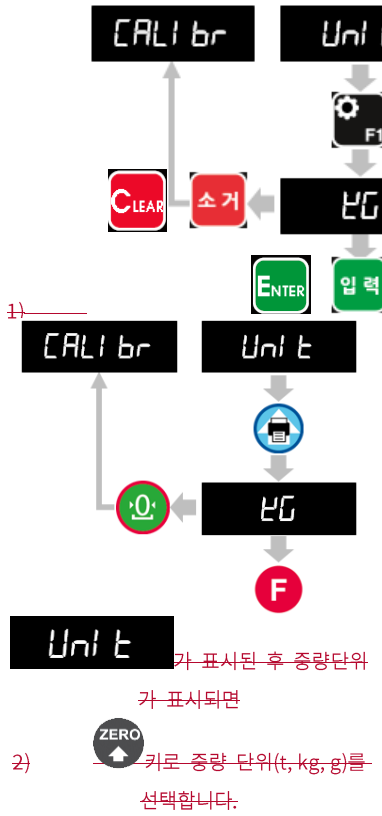

- : Select Unit
- : Save and Move to next step
- 3) - : Cancel and Back to previous step

서식 있음: 표준, 가운데, 글머리 기호 또는 번호 없이

서식 있음: 글꼴: (영어) Noto Sans CJK KR DemiLight, (한글) Noto Sans CJK KR DemiLight, 8 pt

서식 있음: 글꼴: (영어) Noto Sans CJK KR DemiLight, (한글) Noto Sans CJK KR DemiLight, 10 pt, 굵게 없음

서식 있음: 글꼴: (영어) Noto Sans CJK KR DemiLight, (한글) Noto Sans CJK KR DemiLight, 8 pt

서식 있음: 글꼴: (영어) Noto Sans CJK KR DemiLight, (한글) Noto Sans CJK KR DemiLight, 10 pt

서식 있음: 양쪽, 글머리 기호 + 수준:1 + 맞춤 위치: 0.25 cm + 들여쓰기 위치: 0.96 cm

서식 있음: 글꼴: (영어) Noto Sans CJK KR DemiLight, (한글) Noto Sans CJK KR DemiLight, 8 pt

서식 있음: 글꼴: (영어) Noto Sans CJK KR DemiLight, (한글) Noto Sans CJK KR DemiLight, 10 pt

서식 있음: 글꼴: (영어) Noto Sans CJK KR DemiLight, (한글) Noto Sans CJK KR DemiLight, 12 pt, 굵게 없음, 맞춤법 및 문법 검사 안 함

### Step 3. Set Maximum Capacity

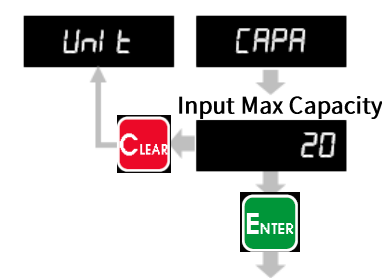

- 1) - : 카:
- 2) - : Save and Move to next step
- 3) - : Cancel and Back to

서식 있는 표

서식 있음: 글머리 기호 + 수준:1 + 맞춤 위치: 0.25 cm + 들여쓰기 위치: 0.96 cm

서식 있음: 글꼴: (영어) Noto Sans CJK KR DemiLight, (한글) Noto Sans CJK KR DemiLight, 8 pt

서식 있음: 글꼴: (영어) Noto Sans CJK KR DemiLight, (한글) Noto Sans CJK KR DemiLight, 10 pt

서식 있음: 양쪽, 줄 간격: 1줄, 글머리 기호 + 수준:1 + 맞춤 위치: 0.25 cm + 들여쓰기 위치: 0.96 cm

서식 있음: 글꼴: (영어) Noto Sans CJK KR DemiLight, (한글) Noto Sans CJK KR DemiLight, 8 pt

서식 있음: 글꼴: (영어) Noto Sans CJK KR DemiLight, (한글) Noto Sans CJK KR DemiLight, 10 pt



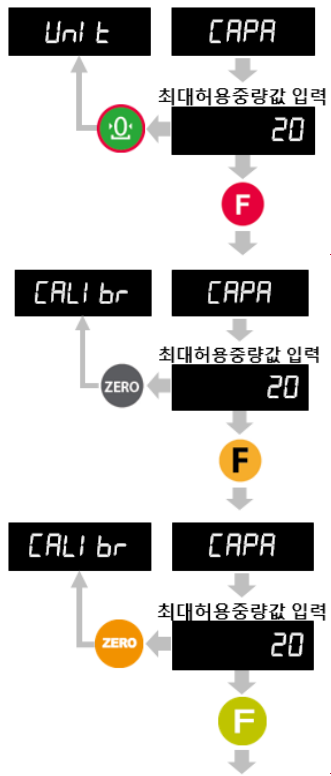

previous step **설정**

Ex : When you want to set 20.00kg (division 0.01kg) for capacity, input 20.

3

#### Step 4. Set Decimal Point and Division

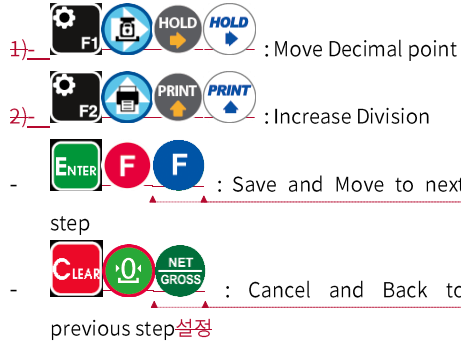
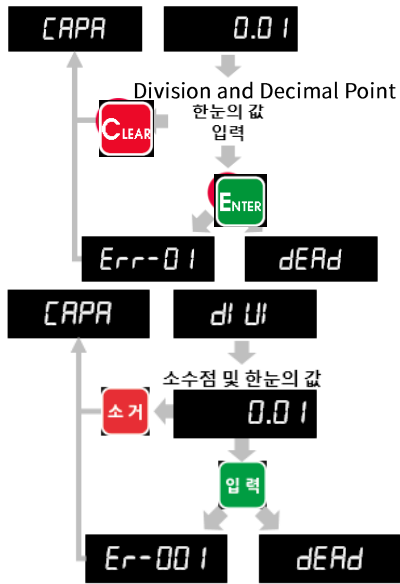

- 서식 있음: 양쪽, 줄 간격: 1줄
- 서식 있음: 글머리 기호 + 수준:1 + 맞춤 위치: 0 cm + 들여쓰기 위치: 0.71 cm
- 서식 있음: 글꼴: (영어) Noto Sans CJK KR DemiLight, (한글) Noto Sans CJK KR DemiLight, 8 pt
- 서식 있음: 글꼴: (영어) Noto Sans CJK KR DemiLight, (한글) Noto Sans CJK KR DemiLight, 10 pt
- 서식 있음: 글꼴: (영어) Noto Sans CJK KR DemiLight, (한글) Noto Sans CJK KR DemiLight, 8 pt
- 서식 있음: 글꼴: (영어) Noto Sans CJK KR DemiLight, (한글) Noto Sans CJK KR DemiLight, 10 pt

- ※ You can set the decimal point to 3 places (0, 0.0, 0.00, 0.000) and division can be set as 1, 2, 5, 10, 20, 50.
- ※ The value of (Max capacity/Division) should not be over 20,000.
- ※ If the value of (Max capacity/Division) is over 20,000, “Er-001” will show up and you have to start from “Step 3. Set Maximum Capacity” again.

#### 4 Step 5. Measure Dead Weight

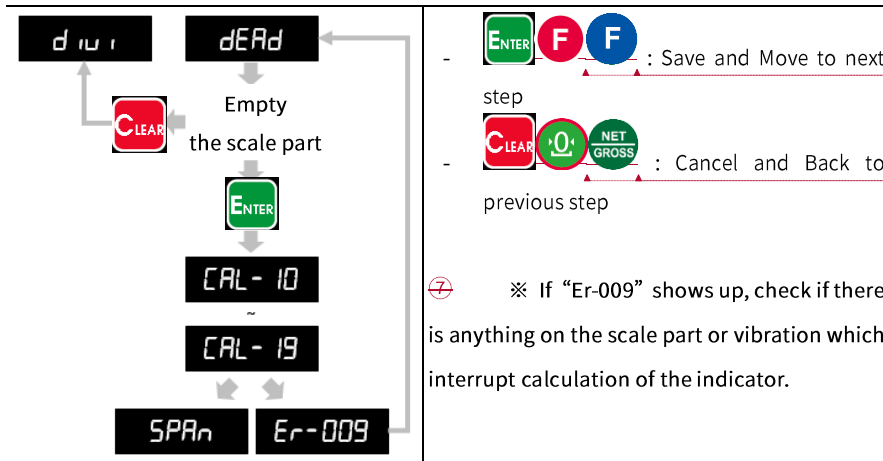

- : Save and Move to next step
  - : Cancel and Back to previous step
- ⊕ ※ If “Er-009” shows up, check if there is anything on the scale part or vibration which interrupt calculation of the indicator.

- 서식 있음: 글꼴: (영어) Noto Sans CJK KR DemiLight, (한글) Noto Sans CJK KR DemiLight, 8 pt
- 서식 있음: 글꼴: (영어) Noto Sans CJK KR DemiLight, (한글) Noto Sans CJK KR DemiLight, 10 pt
- 서식 있음: 글꼴: (영어) Noto Sans CJK KR DemiLight, (한글) Noto Sans CJK KR DemiLight, 8 pt
- 서식 있음: 글꼴: (영어) Noto Sans CJK KR DemiLight, (한글) Noto Sans CJK KR DemiLight, 10 pt
- 서식 있음: 표준, 클머리 기호 또는 번호 없이

## Step 6. Span Calibration

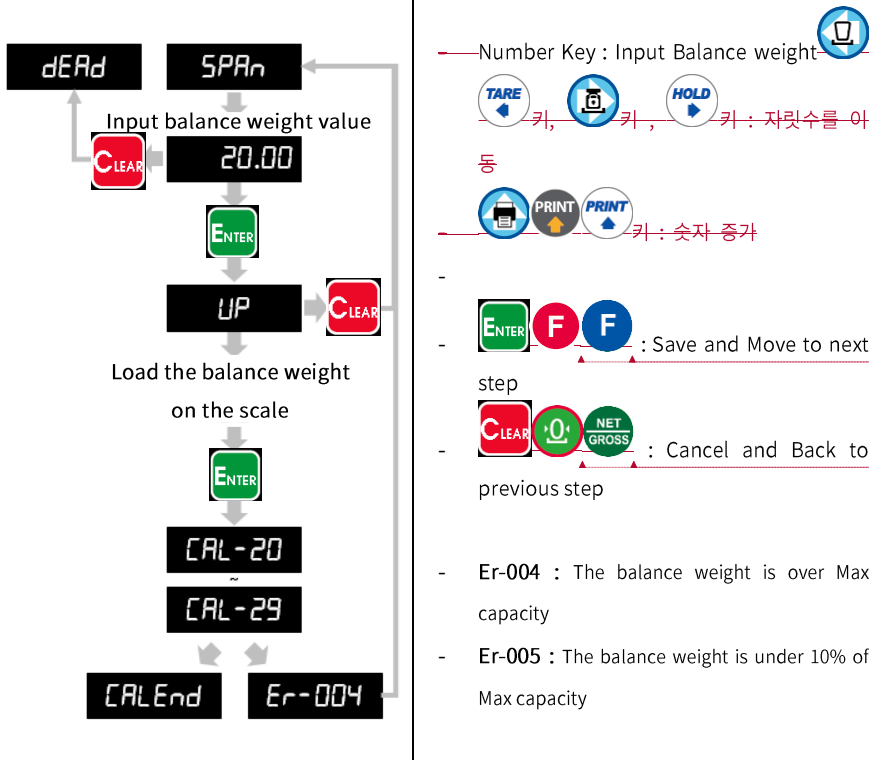

서식 있음: 글꼴: (영어) Noto Sans CJK KR DemiLight,  
(한글) Noto Sans CJK KR DemiLight, 8 pt

서식 있음: 글꼴: (영어) Noto Sans CJK KR DemiLight,  
(한글) Noto Sans CJK KR DemiLight, 10 pt

서식 있음: 글꼴: (영어) Noto Sans CJK KR DemiLight,  
(한글) Noto Sans CJK KR DemiLight, 8 pt

서식 있음: 글꼴: (영어) Noto Sans CJK KR DemiLight,  
(한글) Noto Sans CJK KR DemiLight, 10 pt

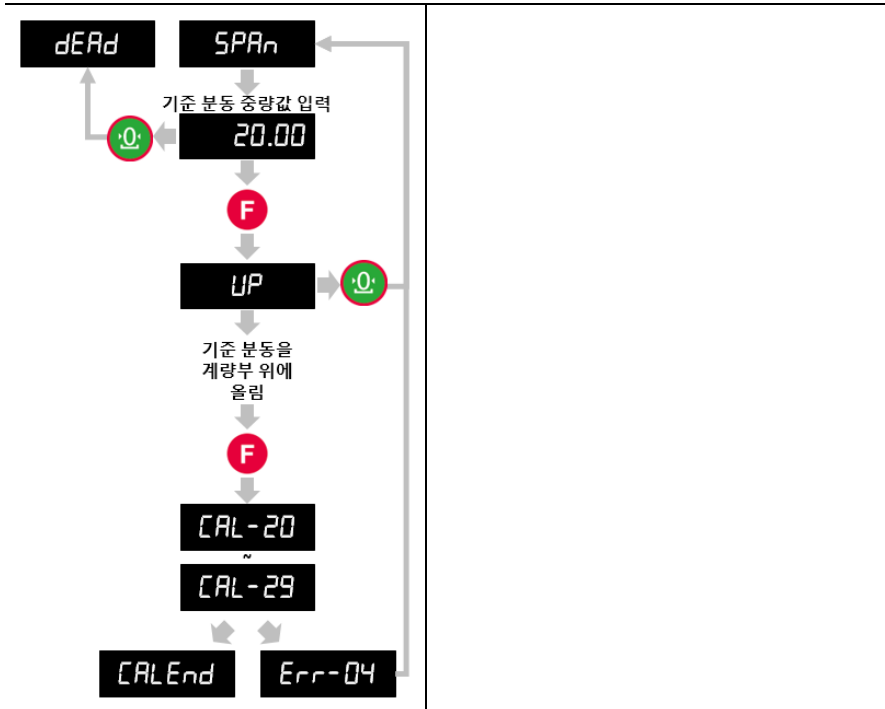

## 5-2. Simulation Calibration

You can proceed with Simulation Calibration when you do not have any balance weight. It is the way to calculate and adjust weight via Max capacity of load cell and Rated Output Value. The guaranteed accuracy of simulation calibration is 1/3,000 and it can differ from the accuracy of Rated Output Value of load cell.

### Step 1. Enter Simulation Calibration Mode

Press CAL Key

CAL br

TARE

LD CAL

ENTER

CAL 키 입력

CAL br



<CAL key position>

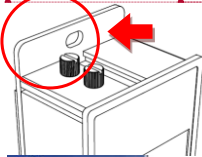

Remove "CAL-BOLT" on the Rear panel and press "CAL key" inside.

<Key Explanation>



- : Select Calibration Mode



- : Save and Move to next step



- : Cancel and Back to previous step

서식 있음: 글꼴: (영어) Noto Sans CJK KR DemiLight, (한글) Noto Sans CJK KR DemiLight, 10 pt

서식 있음: 글꼴: (영어) Noto Sans CJK KR DemiLight, (한글) Noto Sans CJK KR DemiLight, 10 pt

서식 있는 표

서식 있음: 글꼴: (영어) Noto Sans CJK KR DemiLight, (한글) Noto Sans CJK KR DemiLight, 8 pt

서식 있음: 글꼴: (영어) Noto Sans CJK KR DemiLight, (한글) Noto Sans CJK KR DemiLight, 10 pt, 굵게 없음

서식 있음: 글꼴: (영어) Noto Sans CJK KR DemiLight, (한글) Noto Sans CJK KR DemiLight, 8 pt

서식 있음: 글꼴: (영어) Noto Sans CJK KR DemiLight, (한글) Noto Sans CJK KR DemiLight, 10 pt

서식 있음: 글꼴: (영어) Noto Sans CJK KR DemiLight, (한글) Noto Sans CJK KR DemiLight, 8 pt

서식 있음: 글꼴: (영어) Noto Sans CJK KR DemiLight, (한글) Noto Sans CJK KR DemiLight, 10 pt



### Step 3. Set Maximum Capacity



- 4) Number Key, 카: Input Maximum Capacity 자릿수를 이동
- 5) : Save and Move to next step
- 6) : Cancel and Back to previous step **설정**

서식 있는 표

서식 있음: 글머리 기호 + 수준:1 + 맞춤 위치: 0.25 cm + 들여쓰기 위치: 0.96 cm

서식 있음: 글꼴: (영어) Noto Sans CJK KR DemiLight, (한글) Noto Sans CJK KR DemiLight, 8 pt

서식 있음: 글꼴: (영어) Noto Sans CJK KR DemiLight, (한글) Noto Sans CJK KR DemiLight, 10 pt

서식 있음: 양쪽, 줄 간격: 1줄, 글머리 기호 + 수준:1 + 맞춤 위치: 0.25 cm + 들여쓰기 위치: 0.96 cm

서식 있음: 글꼴: (영어) Noto Sans CJK KR DemiLight, (한글) Noto Sans CJK KR DemiLight, 8 pt

서식 있음: 글꼴: (영어) Noto Sans CJK KR DemiLight, (한글) Noto Sans CJK KR DemiLight, 10 pt

MODEL: xxxxx  
**CAPA: 20kg**  
 R.O: 1.429mV/V  
 S/N : xxxxxxxx

- ※ Capacity in Simulation Calibration means the capacity written on load cell label.
- ※ Input the capacity of load cell multiplied by the number of load cell.  
(number of load cell \* capacity of load cell)



<Load Cell Label Explanation >

Step 4. Set Decimal Point and Division

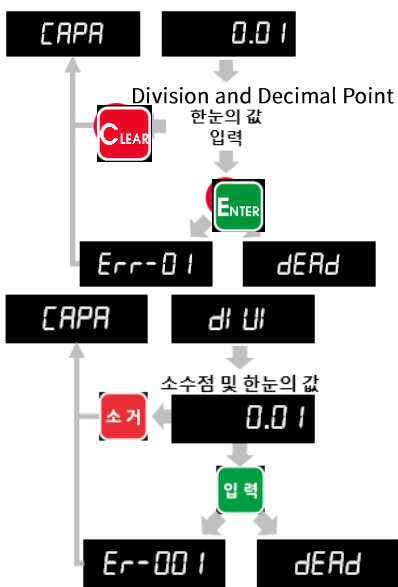

- 서식 있음: 양쪽, 줄 간격: 1줄
- 서식 있음: 글머리 기호 + 수준:1 + 맞춤 위치: 0 cm + 들여쓰기 위치: 0.71 cm
- 서식 있음: 글꼴: (영어) Noto Sans CJK KR DemiLight, (한글) Noto Sans CJK KR DemiLight, 8 pt
- 서식 있음: 글꼴: (영어) Noto Sans CJK KR DemiLight, (한글) Noto Sans CJK KR DemiLight, 10 pt
- 서식 있음: 글꼴: (영어) Noto Sans CJK KR DemiLight, (한글) Noto Sans CJK KR DemiLight, 8 pt
- 서식 있음: 글꼴: (영어) Noto Sans CJK KR DemiLight, (한글) Noto Sans CJK KR DemiLight, 10 pt

- ※ You can set the decimal point to 3 places (0, 0.0, 0.00, 0.000) and division can be set as 1, 2, 5, 10, 20, 50.
- ※ The value of (Max capacity/Division) should not be over 20,000. If the value of (Max capacity/Division) is over 20,000, “Er-001” will show up and you have to start from “Step 3. Set Maximum Capacity” again.

- 서식 있음: 들여쓰기: 왼쪽 0 글자

Step 5. Measure Dead Weight

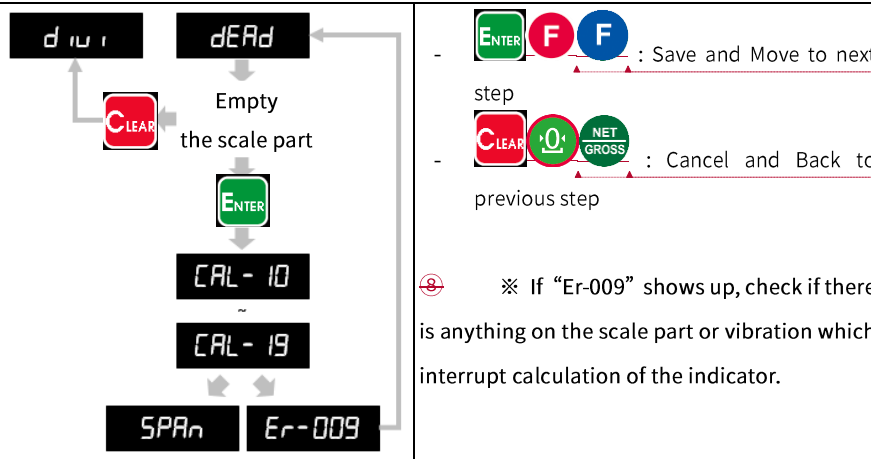

- 서식 있음: 글꼴: (영어) Noto Sans CJK KR DemiLight, (한글) Noto Sans CJK KR DemiLight, 8 pt
- 서식 있음: 글꼴: (영어) Noto Sans CJK KR DemiLight, (한글) Noto Sans CJK KR DemiLight, 10 pt
- 서식 있음: 글꼴: (영어) Noto Sans CJK KR DemiLight, (한글) Noto Sans CJK KR DemiLight, 8 pt
- 서식 있음: 글꼴: (영어) Noto Sans CJK KR DemiLight, (한글) Noto Sans CJK KR DemiLight, 10 pt
- 서식 있음: 표준, 글머리 기호 또는 번호 없이

Step 6. Set R.O.V (Rated Output Voltage/mV)

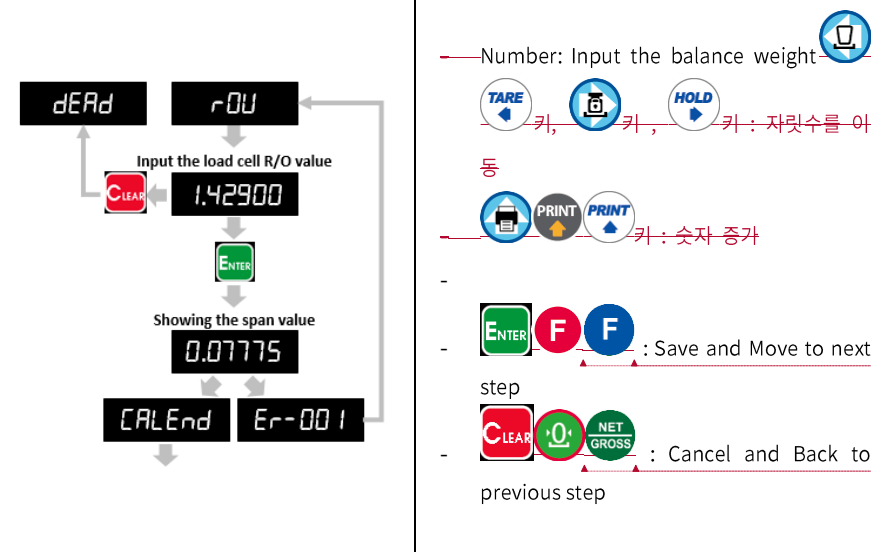

- 서식 있음: 글꼴: (영어) Noto Sans CJK KR DemiLight, (한글) Noto Sans CJK KR DemiLight, 8 pt
- 서식 있음: 글꼴: (영어) Noto Sans CJK KR DemiLight, (한글) Noto Sans CJK KR DemiLight, 10 pt
- 서식 있음: 글꼴: (영어) Noto Sans CJK KR DemiLight, (한글) Noto Sans CJK KR DemiLight, 8 pt
- 서식 있음: 글꼴: (영어) Noto Sans CJK KR DemiLight, (한글) Noto Sans CJK KR DemiLight, 10 pt

MODEL: xxxxx

CAPA: 20kg

R.O: 1.429mV/V

S/N : xxxxxxx

<Load Cell Label Explanation >

-※ “Err-001” means you input wrong value. In this case, you need to check load cell label again.

서식 있음: 글꼴: (영어) Noto Sans CJK KR DemiLight, (한글) Noto Sans CJK KR DemiLight, 굵게

서식 있음: 글꼴: (영어) Noto Sans CJK KR DemiLight, (한글) Noto Sans CJK KR DemiLight, 굵게

서식 있음: 표준, 들여쓰기: 왼쪽: 0 cm, 내어쓰기: 0.5 글자, 첫 줄: -0.5 글자, 글머리 기호 또는 번호 없이

서식 있음: 글꼴: (영어) Noto Sans CJK KR DemiLight, (한글) Noto Sans CJK KR DemiLight, 굵게

서식 있음: 글꼴: (영어) Noto Sans CJK KR DemiLight, (한글) Noto Sans CJK KR DemiLight, 굵게

### 1단계. 등가 화로 중량 조정 모드 진입하기

- 6) 인디케이터 상단에 있는 중량 조정 봉인 볼트(왼쪽)를 제거하고, 내부에 있는 CAL키를 누릅니다.

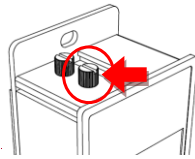

- 7) CAL 1br 가 표시되면 ZERO 키를 누릅니다.

- 8) SETCAL 가 표시되면 F 키를 누릅니다.

- 9) NET GROSS 키로 설정 취소 및 이전 단계로 복귀합니다.

### 2단계. 단위 설정

- 1) Unit 가 표시된 후 중량단위가 표시되면 ZERO 키로 중량 단위(t, kg, g)를 선택합니다.
- 2) F 키를 눌러 저장합니다.
- 3) NET GROSS 키로 설정 취소 및 이전 단계로 복귀합니다.

### 3단계. 최대 허용 중량 값 설정

- 1)  가 표시된 후
- 2)  키와  키를 이용 하여 최대 표시 중량을 설정합니다.
- 3)  키를 눌러 저장합니다.
- 4)  키로 설정 취소 및 이전 단계로 복귀합니다.

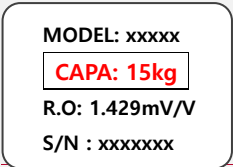

<로드셀 라벨 참고 사진>



분동 캘리브레이션과 달리 CAPA는 로드셀 라벨에 명기되어있는 최대 허용 중량 값을 의미하며 설치된 로드셀의 숫자와 각각의 로드셀의 최대 허용 중량 값을 모두 더한 값을 입력하시기 바랍니다. (로드셀 개수 x 로드셀 최대 허용 중량 값)

### 4단계. 소수점 및 한눈의 값 설정

- 7)  가 표시되면
- 8)  키로 소수점 자리를 이동시키고
- 9)  키로 한눈의 값을 설정합니다.
- 10)  키를 눌러 저장 합니다.
- 11)  키로 설정 취소 및 이전 단계로 복귀합니다.







- 소수점은 세자리(0, 0.0, 0.00, 0.000)까지 설정 가능하고 한눈의 값은 1, 2, 5, 10, 20, 50으로 설정 할 수 있습니다.
- 한눈의 값 설정 시 “최대표시중량/한눈의 값”이 20,000 이상아 되지 않도록 설정 하십시오.
- 만약 20,000 이상으로 설정한 경우에는 “Er-001”이 표기 된 후 최대 표시 중량설정으로 돌아갑니다.

### 5단계. 계량부의 영점 조정

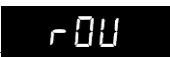
- 5) 가 표시 되면 계량부에 아무것도 없는 상태에서
- 6)  키를 눌러 계량기의 영점에 대한 연산을 시작합니다.
- 7) 가 표시되고 약 10초간 계량부의 영점값을 자동으로 연산하여 저장합니다.

자동 연산 도중 “Er-009”가 표시되면 계량부 위의 내용물이나 외부 간섭 혹은 진동의 원인을 제거한 후 중량 조정을 다시 진행하십시오.

### 6단계. 로드셀 최대 출력값(Rated Output Voltage/mV)입력

- 1)  화면이 표시됩니다.
- 2)  키와  키를 이용 하여 로드셀이나 성적서 상에 표기된 로드셀 최대 출력값(mV/V)을 입력합니다.
- 3)  키를 눌러 저장이 완료되면  화면이 표시됩니다.  
※ “Er-001”이 표시될 경우 잘못된 값을 입력한 경우이므로 다시 한번 로드셀에 부착된 라벨을 확인하시고 진행해 주셔야 바랍니다.
- 4) 등가 상수값이 표시되면  키를 눌러 등가 회로 중량 조정을 완료합니다.

MODEL: xxxxx  
CAPA: 15kg  
**R.O: 1.429mV/V**  
S/N : xxxxxxxx

<로드셀 라벨 참고 사진>

## 5-3. Function Mode

Function Setting makes indicator operate perfectly with surrounding condition.

### 5-3-1. How to enter Function mode

Input the , 4 times in 3 seconds

SET-UP

1

100-01



Move to the function number

Input the function number



Input the setting value



SAVE



101-01



: Change the cursor



: Move the cursor to Function Number







: Move to Function number

input

and save Setting value







: Cancel or Back to previous

step

※ Display Explanation

① ② ③  

① Function Number

② 

: Increase Function Number

③ Setting Value

서식 있는 표

서식 있음: 글꼴: (영어) Noto Sans CJK KR DemiLight, (한글) Noto Sans CJK KR DemiLight, 8 pt

서식 있음: 글꼴: (영어) Noto Sans CJK KR DemiLight, (한글) Noto Sans CJK KR DemiLight, 10 pt

서식 있음: 글꼴: (영어) Noto Sans CJK KR DemiLight, (한글) Noto Sans CJK KR DemiLight, 8 pt

서식 있음: 글꼴: (영어) Noto Sans CJK KR DemiLight, (한글) Noto Sans CJK KR DemiLight, 10 pt

### 5-3-2. Function List

No.	Subject	Default	Content
<b>Function number 100~119 : Indicator system setting</b>			
100	ID Number	01	01~99 ID number
101	Weight Back-up Mode	01	00 : Normal Mode 01 : Zero/Tare Back-Up Mode 02 : Zero Back-Up Mode
102	Weighing Data Saving method	03	00 : Manual (When Print key is input) 01 : Auto (At every steady state) 02 : Auto (At the first steady state) 03 : Auto (After weighing is finished) 04 : Manual or Auto (at every steady state) 05 : Manual or Auto (At the first steady state) 06 : Manual or Auto (After weighing is finished)
104	Display Update Speed	09	01 : 1 time/seconds    07 : 20 time/seconds 02 : 2 time/seconds    08 : 30 time/seconds 03 : 3 time/seconds    09 : 60 time/seconds 04 : 6 time/seconds 05 : 10 time/seconds 06 : 15 time/seconds
106	Under UNPASS/OVERLOAD state, weight display	00	00 : Display 01 : No display
107	Minus (-) mark display	00	00 : Use 01 : No display
108	Buzzer sound (External input detection)	00	00 : Buzzer sound 01 : No Buzzer sound
109	Key input delay time	03	01 ~ 50 (Unit : 0.01 sec)
110	External input delay time	10	01 ~ 50 (Unit : 0.01 sec)

No.	Subject	Default	Content
<b>Function number 120~129 : Print Function</b>			
120	Print Language	00	00 : Korean 01 : English
121	Print Format Setting	00	00 : continuous 01 : continuous (tare/net weight included) 02 : single 03 : single (tare/net weight included) 04 : single array (tare/net weight included)
122	Paper withdraw rate (continuous / single)	00	00 ~ 09 (unit : 1line)
123	Paper withdraw rate (total/ sub-total)	00	00 ~ 09 (unit : 1line)
124	Delete contents after printing sub-total	00	00 : delete 01 : disable
125	Delete contents after printing total	00	00 : delete 01 : disable
<b>Function no. 130~139 : Basic Function Setting for Indicator Weighing System</b>			
130	Steady Range	08	01 ~ 99 (unit : 1 = 0.25 division)
131	Delay to judge Steady state	10	01 ~ 99 (unit : 1 = 0.1 sec)
132	Digital Filter	25	01(weak vibration) ~ 50(strong vibration)
133	Auto Zero Range	00	01 ~ 99 (unit : 1 = 0.25 division)
134	Zero Key Operation	00	00 : No limit 01 : Active only under steady condition
135	Zero Key Range	02	00 : less than 2% of Max Capacity 01 : less than 5% of Max Capacity 02 : less than 10% of Max Capacity 03 : less than 20% of Max Capacity 04 : less than 50% of Max Capacity 05 : less than 100% of Max Capacity 06 : No limit



No.	Subject	Default	Content	
<b>Function number 140~199 : External Input and Relay Out Setting</b>				
140	Relay Auto / Manual Setting	00	00: Auto	01 : Manual
141	Relay Out 1	xx	00 : Disuse	07 : Under
142	Relay Out 2	xx	01 : SP1	08 : Over
143	Relay Out 3	xx	02 : SP2	09 : Error
144	Relay Out 4	xx	03 : SP3	10 : Near Zero
145	Relay Out 5	xx	04 : SP4	11 : Running
146	Relay Out 6	xx	05 : Finish	12 : 2-Stage
147	Relay Out 7	xx	06 : Target	charge
148	Relay Standard (A, B contact)	00	00: Auto	01 : Manual
149	Relay Out Standard 1	00	00: A contact 01: B contact	
150	Relay Out Standard 2	00		
151	Relay Out Standard 3	00		
152	Relay Out Standard 4	00		
153	Relay Out Standard 5	00		
154	Relay Out Standard 6	00		
155	Relay Out Standard 7	00		
156	External Input 1 setting	01	00 : Disuse	06 : Stop
157	External Input 2 setting	04	01 : Zero	07 : Run/Stop
158	External Input 3 setting	07	02 : Tare	08 : Judgement
159	External Input 4 setting	11	03 : Tare reset	Input
160	External Input 5 setting	13	04 : Tare/tare reset	09 : Forced finish
161	External Input 6 setting	14	05 : Run	10 : Print 11 : Print Sub-total 12 : Print Total

No.	Subject	Default	Content
<b>Function no. 200~209 : Basic Serial Interface (RS232C/Current Loop) Setting</b>			
<b>Function no. 210~219 : Option Serial Interface (RS232C/RS422/RS485) Setting</b>			
200	Data bit/Stop bit/ Parity	00	00: Data bit8, Stop bit1, Parity bit Non
210 (Option)			01: Data bit8, Stop bit1, Parity bit Odd 02: Data bit8, Stop bit1, Parity bit Even 03: Data bit7, Stop bit1, Parity bit Non 04: Data bit7, Stop bit, Parity bit Even
201	Baud Rate	02	00 : 2,400bps      05 : 28,800bps
211 (Option)			01 : 4,800bps      06 : 38,400bps 02 : 9,600bps      07 : 57,600bps 03 : 14,400bps     08 : 76,800bps 04 : 19,200bps     09 : 115,200bps
202	Communication Mode	00	00: Stream mode
212 (Option)			01: Command mode 02: Command mode(SI 4410 format) 03: Print mode 04: Modbus (RTU)
203	Serial Interface Stream Mode Protocol (F202-00 / F212-00)	00	00 : format1 (18byte)
213 (Option)			01 : format2 (21byte) 02 : format3 (17byte) 03 : format4 (22byte) 04 : format5 (15byte)
204	Stream Mode Data Output (F202-00 / F212-00)	00	00 : continuous
214 (Option)			01 : 1 time at every steady state 02 : 1 time at the first steady state (over Near Zero) 03 : 1 time after weighing is finished 04 : Input Print key or using external device
205	Command Checksum	00	00 : Disuse
215 (Option)			01 : Use

No.	Subject	Default	Content
<b>Function number 250~259 : Option Ethernet Interface Setting</b>			
252	Ethernet Interface Communication Mode	03	00: Stream mode 01: Command mode 02: Command mode(SI 4410 format) 03: Modbus TCP/IP
253	Ethernet Interface Stream Mode Protocol (F252-00)	00	00 : format1 (18byte) 01 : format2 (22byte) 02 : format3 (17byte) 03 : format4 (22byte) 04 : format5 (15byte)
254	Ethernet Interface Stream Mode Data Output (F252-00)	00	00 : continuous 01 : 1 time at every steady state 02 : 1 time at the first steady state (over Near Zero) 03 : 1 time after weighing is finished 04 : Input Print key or using external device
255	Ethernet "Check-Sum" under command mode	00	00 : Disuse 01 : Use

※ Remark: Set F250-00 for BCD OUT option

※ Unable to use Ethernet and BCD OUT simultaneously.

<b>Function number 300~309 : Option Analog Output Interface Setting</b>			
300	Analog Output Direction	00	00 : Forward (4~20mA, 0→10V) 01 : Reverse (20~4mA, 10→0V)
301	Analog Max Output Range	00	00 : Absolute value (regardless of mark "-" or "+") 01 : Positive value (Output when current weight is "+")

No.	Subject	Default	Content
302	Analog Max Output (Iout=20mA, Vout=10V) Standard	00	00 : Max capacity 01 : SP1 value 02 : SP2 value 03 : SP3 value 04 : SP4 value 05 : Max capacity (Gross value under Tare state)
<b>Function number 310~319 : Option BCD IN Interface (Part Number Input)</b>			
310	BCD IN Interface (External Part Number Input)	00	00: Disuse 01: Unit digit(4bit) and Tenth digit(4bit) 02: Input value by binary (8bit) 03: Absolute value (IN1=1~IN8=8)
<b>Function number 330~339 : Option Data storage Device (SD memory card)</b>			
330	SD Memory Card	00	00 : disable 01 : enable ("Sd-err" displays if SD card is not inserted)
331	SD Auto Data Save	01	00 : disable 01 : enable
<b>Function number 501~599 : Indicator weighing process</b>			
500	Weighing Mode	01	00 : disuse 01 : Limit Mode (A Contact) 02 : 3-Stage Discharge Mode_1 03 : 3-Stage Discharge Mode_2 04 : 2-Stage Charge 2-Stage Discharge Mode_1 05 : 2-Stage Charge 2-Stage Discharge Mode_2 06 : 2-Stage Charge 2-Stage Discharge Mode_3 07 : 1-Stage Charge 2-Stage Discharge Mode (compatible with SI4410)
501	Weighing Method Setting	00	00 : Absolute value 01 : Positive value
502	Zero State Lamp	00	00 : Near Zero (Absolute value) 01 : Zero 02 : Near Zero (Positive value)

No.	Subject	Default	Content
503	Control Weight Setting	00	00 : Setting Value Standard 01 : Setting Value-Bulk or Drib
510	Finish Relay Delay Time	10	00 : Relay out right after Steady state 20 : Relay out after 2.0 sec 99 : Relay out after 9.9 sec
520	Finish Relay Output Time	10	01 : Relay out for 0.1 sec 20 : Relay out for 2.0 sec
521	Judgement Relay Output Time	10	00 : until weight reaches Near Zero range 01 : Relay out for 0.1 sec 20 : Relay out for 2.0 sec
522	Error Relay Output Time	10	00 : until weight reaches Near Zero range 01 : Relay out for 0.1 sec 20 : Relay out for 2.0 sec
523	Discharge Relay Output Time	00	00 : until weight reaches Empty range 20 : Discharge Relay out for 2 sec
530	Tare Setting Method	00	00 : Tare key 01 : Input with number keys 02 : Input with number key after Tare key
531	Tare Operation limit	00	00 : No limit 01 : Active only under steady condition
532	Tare Operation range	02	00 : less than 10% of Max Capacity 01 : less than 20% of Max Capacity 02 : less than 50% of Max Capacity 03 : less than 100% of Max Capacity
533	Tare Operation Delay Time	00	00 : disable 01 ~ 10 : enable (Unit : 1 sec)
534	Auto Zero After Tare Key Input	00	00 : disable            01 : enable
535	Zero Lamp During Tare State	00	00 : ON when displayed weight is zero 01 : ON when gross weight excluding tare weight

No.	Subject	Default	Content
536	Auto tare for "RUN"	00	00 : disable 01 : enable
537	Auto Tare Reset	00	00 : disable (Manual reset) 01 : Auto Reset under Near Zero range 02 : Auto Reset under Steady state 03 : Auto Reset after weighing finishes
538	Auto Tare Reset Delay Time	00	00 : disable (right after Key or External input) 00 ~ 09 : enable (Unit : 1 second)
551	Drib Control	00	00 : disable 01 : enable ※ If finish weight is under PRESET value within finish relay delay time, Drib Relay OUT
552	Auto Free Fall Adjustment	00	00 : disable 01~10 : enable
557	Charge Method Setting	00	0 : Start charging when current weight is lighter than SP2 (supply) 1 : Start charging when current weight is lighter than SP4 (output)

◆ Weighing mode – F500-01 : Limit mode 1 (A Contact)

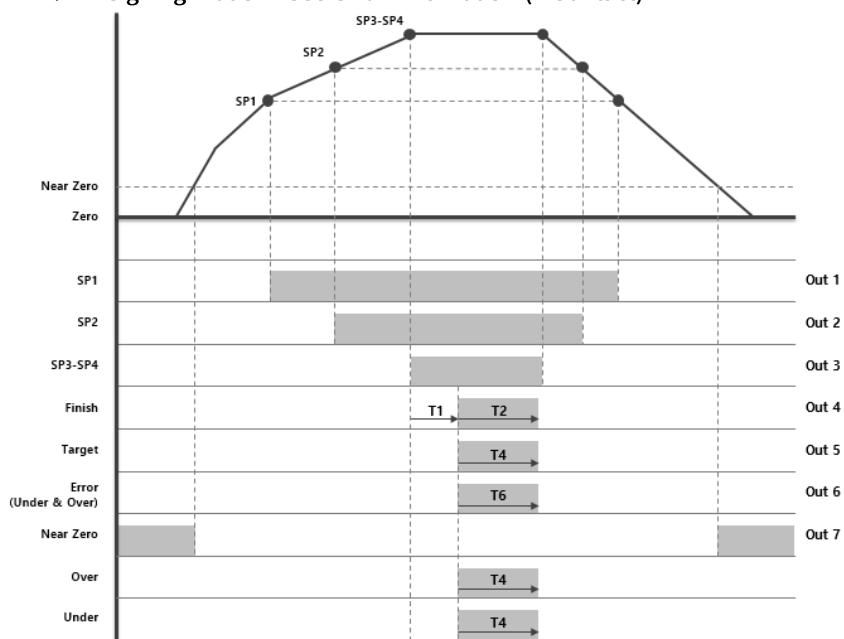

T1	Finish Relay Delay Time (F510)	T2	Finish Relay Output Time (F520)
T3	Judgement Relay Output Time (F521)	T4	Error Relay Output Time (F522)

Relay	Output		Relay	Output
OUT 1	ON	Current weight $\geq$ SP1	OUT 5	SP3-Under $\leq$ Current weight $\leq$ SP3+Over
	OFF	Current weight $<$ SP1		During T4 after T1
OUT 2	ON	Current weight $\geq$ SP2	OUT 6	Current weight $\leq$ SP3-Under or SP3+Over $\leq$ Current weight
	OFF	Current weight $<$ SP2		During T6 after T1
OUT 3	ON	Current weight $\geq$ SP3-SP4	OUT 7	ON within Near Zero range(HF12)
	OFF	Current weight $<$ SP3-SP4		
OUT 4	During T2 after T1			

※ Relay Off within Near Zero range if T2,T4,T6 are set as '0'.

◆ Weighing mode – F500-02 : 3-Stage Discharge Mode\_1

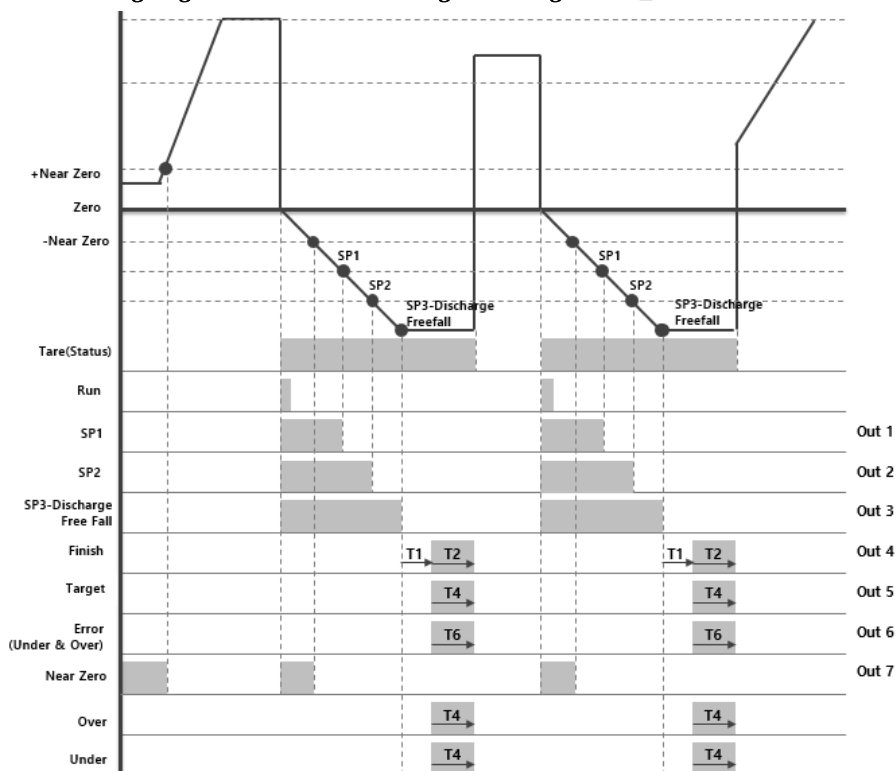

T1	Finish Relay Delay Time (F510)	T2	Finish Relay Output Time (F520)
T4	Judgement Relay Output Time (F521)	T6	Error Relay Output Time (F522)

Relay	Output		Relay	Output
OUT 1	ON	Input Run	OUT 5	SP3-Under ≤ Current weight ≤ SP3+Over
	OFF	Current weight ≥ SP1		During T4 after T1
OUT 2	ON	Input Run	OUT 6	Current weight ≤ SP3-Under or SP3+Over ≤ Current weight
	OFF	Current weight ≥ SP2		During T6 after T1
OUT 3	ON	Input Run	OUT 7	ON within Near Zero range (HF12)
	OFF	Current weight ≥ SP3 - Discharge free fall		
OUT 4	During T2 after T1			

※ Relay Off within Near Zero range if T2, T4, T6 are set as '0'.



◆ Weighing mode – F500-03 : 3-Stage Discharge Mode\_2

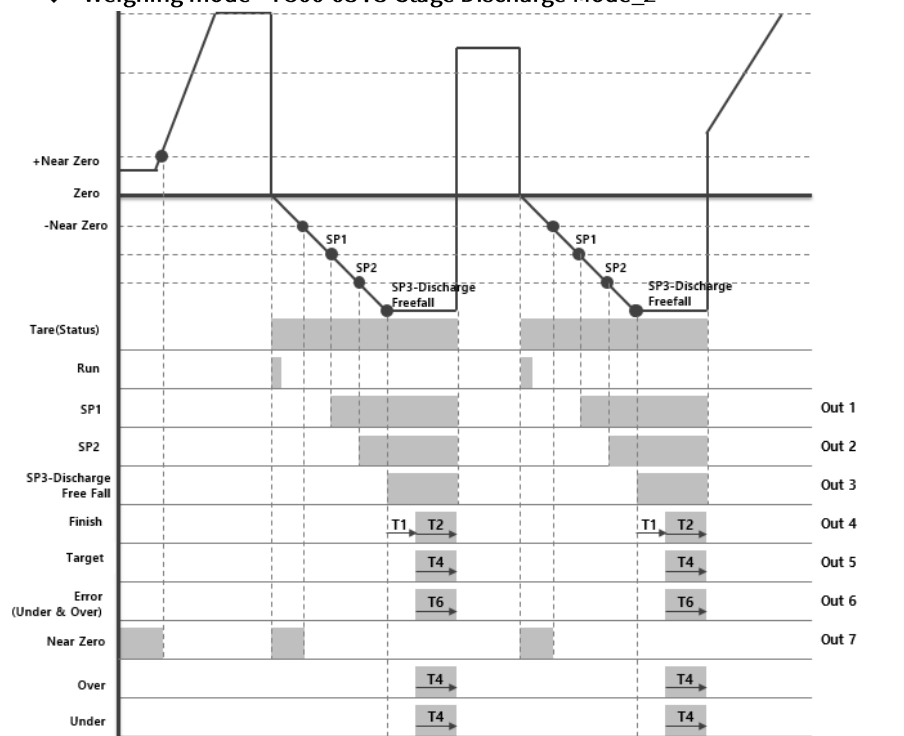

T1	Finish Relay Delay Time (F510)	T2	Finish Relay Output Time (F520)
T4	Judgement Relay Output Time (F521)	T6	Error Relay Output Time (F522)

Relay	Output		Relay	Output
OUT 1	ON	Current weight $\geq$ SP1	OUT 5	SP3-Under $\leq$ Current weight $\leq$ SP3+Over During T4 after T1
	OFF	Weighing finishes		
OUT 2	ON	Current weight $\geq$ SP2	OUT 6	Current weight $\leq$ SP3-Under or SP3+Over $\leq$ Current weight During T6 after T1
	OFF	Weighing finishes		
OUT 3	ON	Current weight $\geq$ SP3 - Discharge free fall	OUT 7	ON within Near Zero range(HF12)
	OFF	Weighing finishes		
OUT 4	During T2 after T1			

※ Relay Off within Near Zero range if T2,T4,T6 are set as '0'.

◆ Weighing mode – F500-04 : 2-Stage Charge 2-Stage Discharge Mode\_1

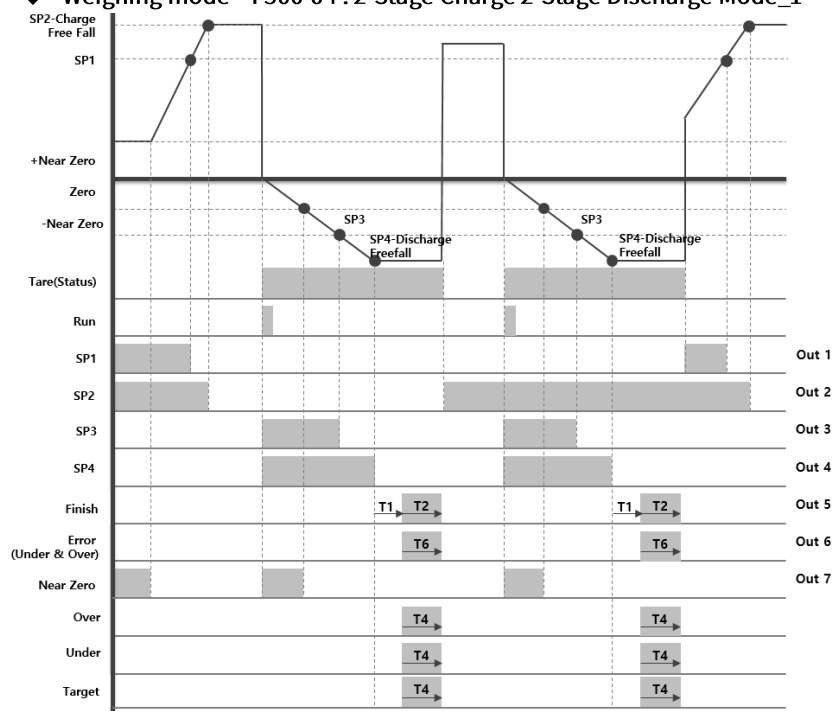

T1	Finish Relay Delay Time (F510)	T2	Finish Relay Output Time (F520)
T4	Judgement Relay Output Time (F521)	T6	Error Relay Output Time (F522)

Relay	Output		Relay	Output
OUT 1	ON	Current weight < SP1	OUT 5	During T2 after T1
	OFF	Current weight ≥ SP1		
OUT 2	ON	Current weight < SP2 - Charge free fall	OUT 6	Current weight ≤ SP4-Under or SP4+Over ≤ Current weight During T6 after T1
	OFF	Current weight ≥ SP2 - Charge free fall		
OUT 3	ON	Input Run	OUT 7	ON within Near Zero range(HF12)
	OFF	Current weight ≥ SP3		
OUT 4	ON	Input Run		
	OFF	Current weight ≥ SP4 - Discharge free fall		

※ Relay Off within Near Zero range if T2,T4,T6 are set as '0'.

◆ Weighing mode – F500-05 : 2-Stage Charge 2-Stage Discharge Mode\_2

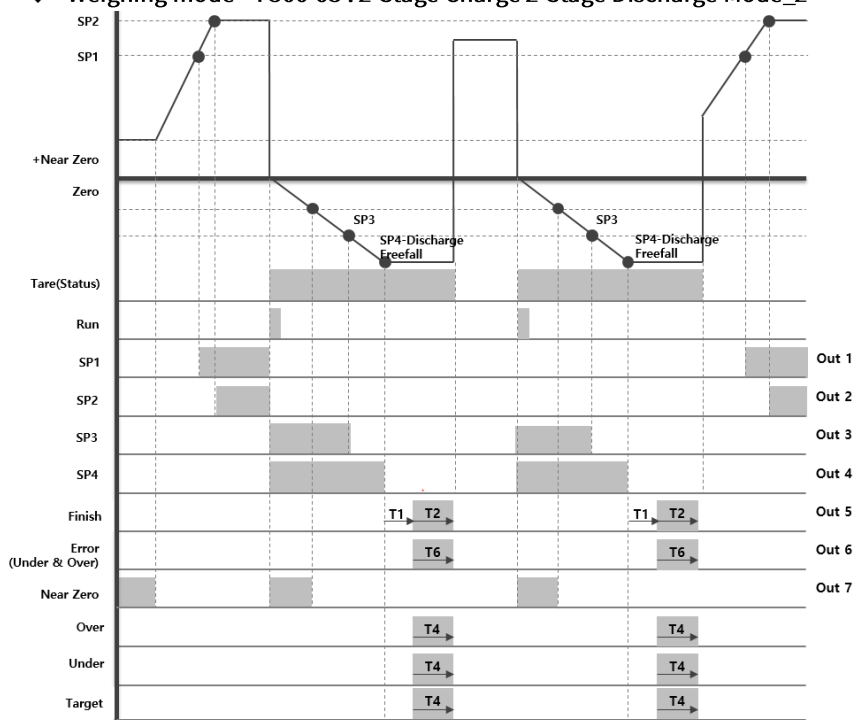

T1	Finish Relay Delay Time (F510)	T2	Finish Relay Output Time (F520)
T4	Judgement Relay Output Time (F521)	T6	Error Relay Output Time (F522)

Relay	Output		Relay	Output
OUT 1	ON	Current weight $\geq$ SP1	OUT 5	During T2 after T1
	OFF	Current weight $<$ SP1		
OUT 2	ON	Current weight $\geq$ SP2 - Charge free fall	OUT 6	Current weight $\leq$ SP4-Under or SP4+Over $\leq$ Current weight During T6 after T1
	OFF	Current weight $<$ SP2 - Charge free fall		
OUT 3	ON	Current weight $\geq$ SP3	OUT 7	ON within Near Zero range(HF12)
	OFF	Weighing finishes		
OUT 4	ON	Current weight $\geq$ SP4 - Discharge free fall		
	OFF	Weighing finishes		

※ Relay Off within Near Zero range if T2,T4,T6 are set as '0'.

◆ Weighing mode – F500-06 : 2-Stage Charge 2-Stage Discharge Mode\_3

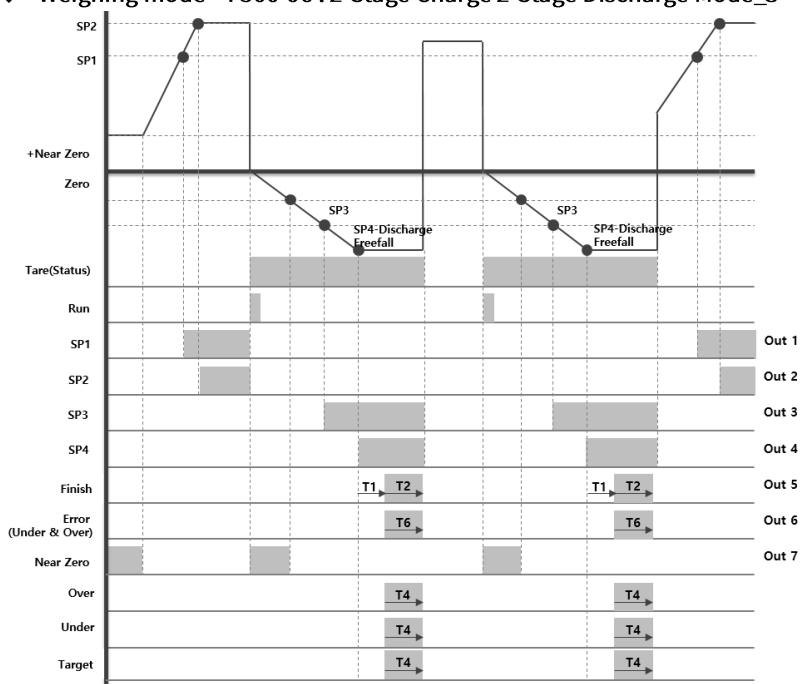

T1	Finish Relay Delay Time (F510)	T2	Finish Relay Output Time (F520)
T4	Judgement Relay Output Time (F521)	T6	Error Relay Output Time (F522)

Relay	Output		Relay	Output
OUT 1	ON	Current weight < SP1	OUT 5	During T2 after T1
	OFF	Current weight ≥ SP1		
OUT 2	ON	Current weight < SP2 – Charge free fall	OUT 6	Current weight ≤ SP4-Under or SP4+Over ≤ Current weight During T6 after T1
	OFF	Current weight ≥ SP2 – Charge free fall		
OUT 3	ON	Current weight ≥ SP3	OUT 7	ON within Near Zero range(HF12)
	OFF	Weighing finishes		
OUT 4	ON	Current weight ≥ SP4 – Discharge free fall		
	OFF	Weighing finishes		

※ Relay Off within Near Zero range if T2,T3,T4 are set as '0'.

◆ Weighing mode – F500-07 : 1-Stage Charge 2-Stage Discharge Mode  
(compatible with SI4410)

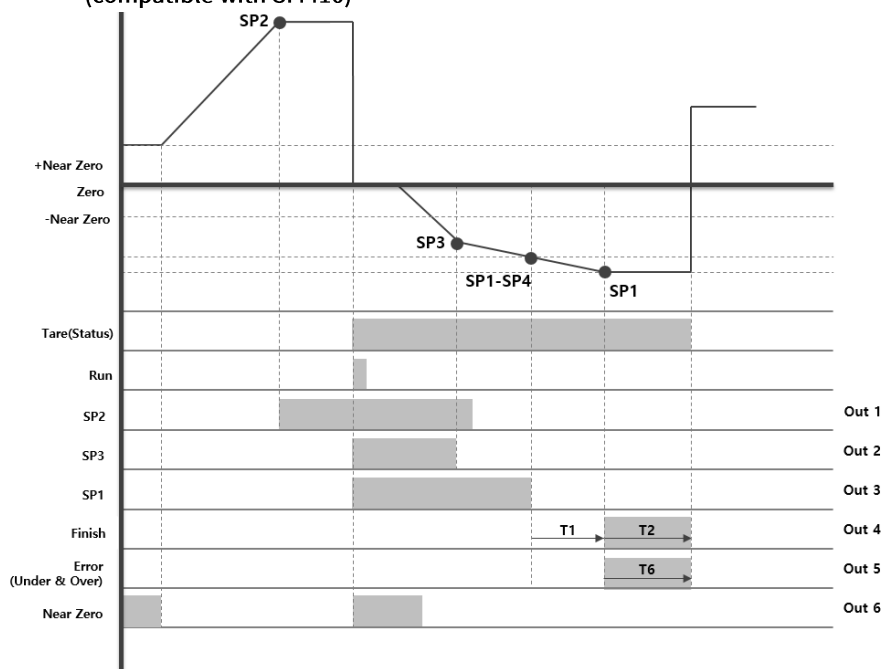

T1	Finish Relay Delay Time (F510)	T2	Finish Relay Output Time (F520)
T6	Error Relay Output Time (F522)		

Relay	Output		Relay	Output
OUT 1	ON	Current weight $\geq$ SP2	OUT 4	During T2 after T1
	OFF	Current weight $<$ SP2		
OUT 2	ON	Current weight $<$ SP3	OUT 5	Current weight $\leq$ SP1-Under or SP1+Over $\leq$ Current weight During T6 after T1
	OFF	Current weight $\geq$ SP3		
OUT 3	ON	Current weight $<$ SP1-SP4	OUT 6	ON within Near Zero range(HF12)
	OFF	Current weight $\geq$ SP1-SP4		

※ Relay Off within Near Zero range if T2 is set as '0'.

### ◆ 5-3-3. Hidden Function Mode

※ How to enter Hidden Function Mode

Press  4 times within 3seconds

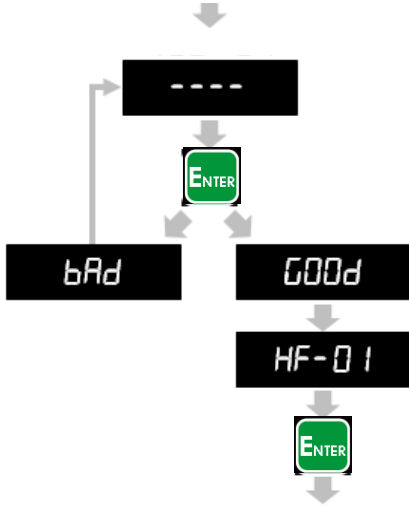

Number key: Input password

  :

Increase or decrease number

   : Save or Move to next

step

   : Cancel or Back to previous step

서식 있음: 글머리 기호 + 수준:1 + 맞춤 위치: 0.25 cm + 들여쓰기 위치: 0.96 cm, 탭: 3.6 글자(없음)





서식 있음: 글꼴: (영어) Noto Sans CJK KR DemiLight, (한글) Noto Sans CJK KR DemiLight, 8 pt



서식 있음: 글꼴: (영어) Noto Sans CJK KR DemiLight, (한글) Noto Sans CJK KR DemiLight, 10 pt

서식 있음: 글꼴: (영어) Noto Sans CJK KR DemiLight, (한글) Noto Sans CJK KR DemiLight, 8 pt

서식 있음: 글꼴: (영어) Noto Sans CJK KR DemiLight, (한글) Noto Sans CJK KR DemiLight, 10 pt

No.	Subject	Default	Remarks
HF01	Serial Number	xxxxx	Factory release number
HF02	Software Version	Ver 3.10	
HF03	Hardware Version	Ver 1.xx	
HF04	Date	YY.MM.DD	Able to set using keys
HF05	Time	HH.MM.SS	Able to set using keys
HF06	Password Setting - Password setting for Hidden Function Mode (4 digits) - Input password twice to check	----	Able to set using keys

No.	Subject	Default	Remarks
HF07	Function Reset	FUNSET	 for "YES"-> Press  to proceed with reset.  for "NO"-> Press  to cancel reset.
HF08	Factory Reset	ALLSET	
HF10	Max Capacity	15.000	Change after calibration
HF11	Span Constant	x.xxxxx	
HF12	Near Zero Range	0.000	Able to set using keys
HF13	Use Simulation Calibration	00	00 : disuse 01 : use
HF14	Span Value Input	OrnU	Input Span Value with Calibrator
HF15	Simulation Calibration Constant Value	x.xxxxx	
<b>Option Analog Output Interface Setting (HF20-HF22)</b>			
HF20	Analog Output Setting	00	00 : Iout(4-20mA) 01 : Vout(0-10V)
HF21	Minimum Analog Output Adjustment (Current/Voltage)	0.00	Input $\pm$ gap value (F1 for minus mark '-')
HF22	Maximum Analog Output Adjustment (Current/Voltage)	0.00	

No.	Subject	Default	Remarks
Option Ethernet Interface Setting (HF30~HF49)			
HF30 ~ HF33	IP ADDRESS (1~4)	192.168.0.101	Able to set using keys and press  key to set it.
HF34 ~ HF37	GateWay (1~4)	192.168.0.1	
HF38 ~ HF41	SubNet mask (1~4)	255.255.255.0	
HF42	Port Number	5000	
HF43 ~ HF46	SERVER IP ADDRESS 1 ~ 4	192.168.0.100	
HF47	Communication 0 : Server mode - Stream mode (F252-00) - Command mode (F252-01) Sending the date to IP 1 : Client mode Transmit the data to IP that setting on HF43~46 or HF42 Port	0	Able to set using keys and press  key to set it.











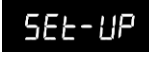

## 5-4. Test mode



Disconnect all of the devices from the indicator before you proceed with test.

How to enter Test Mode

- 1) Press  4 times for 3 seconds.
- 2) When  displays, press .
- 3) When  displays,
- 4) You can select test various modes as below. .



Key	Test	Key	Test
	Load Cell Input Value Check Mode		External Input Check Mode
	Load cell Input Value Fluctuation Check Mode		Relay Out Check Mode
	Keypad Check Mode		Analog Output 4~20mA, 0~10V Check Mode
	Display Check Mode		

- 5)  to cancel or move to previous step.

### 5-4-1. Load Cell Input Value Check Mode





- 1) Press  on the test mode to check value.
  - ※ This mode is to check analog input value converted to digital value. It is normal symptom that the last digit changes.  
(-1,048,575~1,048,575 can be displayed)
  - ※ If the value is fluctuating though there is nothing on the scale part or if there is no difference when you load something on the scale part, these may be because of broken load cell, cable connection error, or broken A/D converter of indicator.





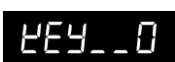









### 5-4-2. Load Cell Input Value Fluctuation Check Mode

- 1) Press  on the test mode.
- 2) Press  to display . In this condition, the weight loaded on the scale part converted to digital value so you can check the deviation of change of weight.

### 5-4-3. Keypad Check Mode

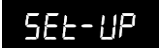

You can check key operation on display.

- 1) Press  on the test mode, then  displays.
- 2) When you push a key except for , relevant numbers will show up on display.
- 3) Press  key to back to .

KEY	DISPLAY	KEY	DISPLAY	KEY	DISPLAY
	1		6		10
	2		7		11
	3		8		12
	4		9		13
	5		0		Back to 

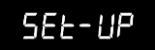

#### 5-4-4. Display Check Mode

---

- 1) Press  on the test mode to check display condition.
  - 2) You can check display condition.
  - 3) Press  to back to .
- 



#### 5-4-5. External Input Check Mode







---

- 1) Press  on the test mode, then  displays.
  - 2) Wire External Input terminal and Input common Terminal (IC) to check External Input number on display..
- 

#### 5-4-6. Relay Out Check Mode

---



- 1) Press  on the test mode for  display.
- 2) You can check selected relay output.  
※ Disconnect all of the devices from indicator before you proceed with tests.

						
OUT1 ON/OFF	OUT2 ON/OFF	OUT3 ON/OFF	OUT4 ON/OFF	OUT5 ON/OFF	OUT6 ON/OFF	OUT7 ON/OFF

---

### 5-4-7. Analog Output 4~20mA, 0~10V Check Mode

---

- 1) Press  on the test menu, then  will display.
- 2) You can proceed with simulation With indicator outputting virtual analog output from In00.000(0mA, 0V) to 23.000(23mA, 10V).
- 3) A means Analog output 4 ~ 20mA, V means 0 ~ 10V.

※ You can check analog output by 0.1 unit with arrow keys.

If input value is over the maximum, real output will be 100%.

EX) If the mode is 4~20mA and you input **4.000**, the real output will be **4mA**.

If the mode is 4~20mA and you input **20.000**, the real output will be **20mA**.

If the mode is 0~10V and you input **4.700**, the real output will be **4.7V**.

If the mode is 0~10V and you input **10.000**, the real output will be **10V**.

---

## 6. Option card

### 6-1. Serial interface

#### 6-1-1. Serial interface OP-01 : RS422

RS422 Interface is available for long-distance communication (within 1km) since it is strong against electric noise. You can connect up to 32EA of devices like PC, PLC, Printer through Multi-Drop Method.

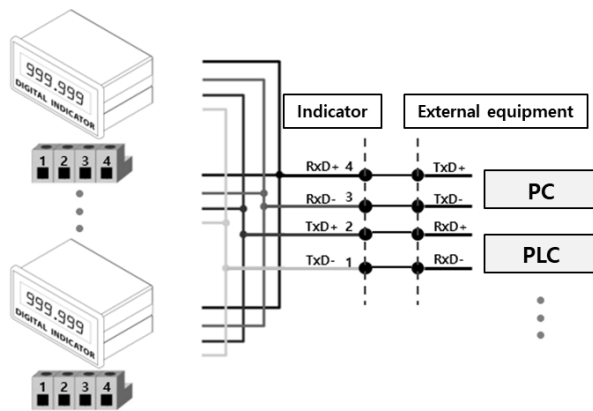

#### 6-1-2. Serial interface OP-02 : RS485

RS485 Interface is available for long-distance communication (within 1km) since it is strong against electric noise. Although this Interface is slow compared to RS422, but you can connect up to 32EA of devices like PC, PLC, Printer through Multi-Drop Method.

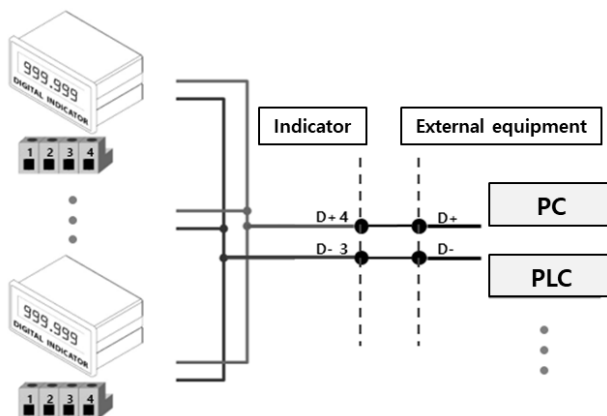

### 6-1-3. Serial interface OP-03 : RS232C

RS232C Interface is adequate for short distance communication like PC, PLC, printer, external display and etc since it is weak in electric noise.

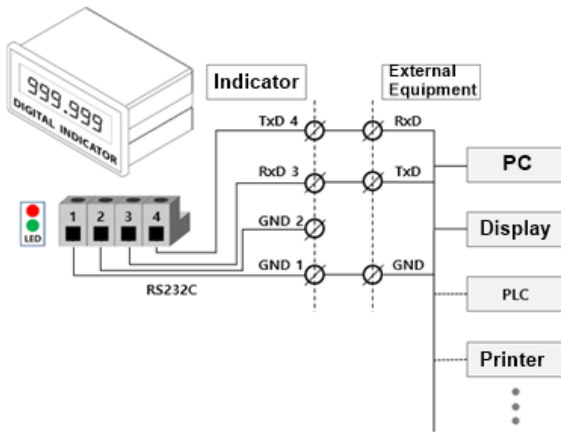

Since Serial Interface is vulnerable to electric noise, Use twisted shielded cable to minimize communication disruption.

## 6-2. Ethernet Interface

### 6-2-1. Ethernet Interface : OP-04

Connect Indicator to External Devices like PC through Ethernet Interface.

(Baud rate: 10/100Mbps)

- Function 252-00 (Stream mode)
- Function 252-01 (Command mode)
- Function 252-03 (Modbus TCP/IP)

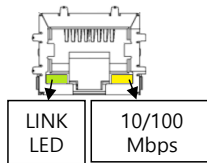

## 6-3. Analog output

### ※ How to select Analog Output (Iout or Vout)

Switch Iout or Vout through a deep switch installed inside of Indicators or option cards.

Select Analog Output option on HF13 and save the setting value.

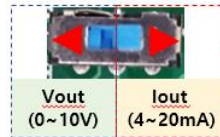

### 6-3-1. Analog Current Output (4~20mA) : OP-05

Analog Output Interface 4~20mA transmit displayed weight data to the external devices like PC, recorder, PLC, external display, etc through current output.

Current Output	Accuracy	Temperature Coefficient	Max Load Impedance
4mA ~ 20mA	1/1,000	0.01%/°C	500Ω MAX.



- Analog Output does not work during calibration or Ad-Err.
- If it stop working, the last value maintains.
- It is not adequate for the system which demands high-accuracy over 1/1,000.

#### 1) Circuit Composition and Connection

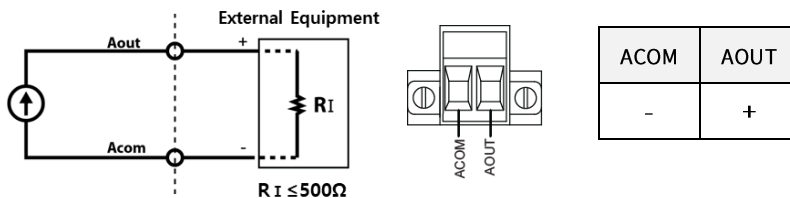

Analog Current Output Interface transmit analog current(4~20mA) commensurate with the displayed weight

#### 2) Analog Current Output Adjustment (HF20-00)

- ① Default is : 4mA output for Zero, 20mA output for Max Capacity.
- ② If there is a gap in value caused by distance or environment, the way to adjust is as following ③.
- ③ How to adjust Analog Output
  - When the weight is zero but output is not 4mA, You can adjust the gap on HF21.
  - When the weight is Max Capacity but output is not 20mA, You can adjust the gap on HF22.

### 6-3-2. Analog Voltage Output (0~10V)

Analog Output Interface 0~10V transmit displayed weight data to the external devices like PC, recorder, PLC, external display, etc through voltage output.

Output voltage	0~10VDC output
Accuracy	1/1,000



- Analog Output does not work during calibration or Ad-Err.
- If it stop working, the last value maintains.
- It is not adequate for the system which demands high-accuracy over 1/1,000.

#### 1) Circuit Composition and Connection

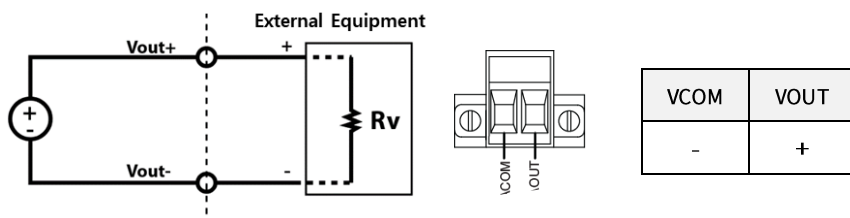

Analog Voltage Output Interface transmit analog voltage(0~10V) commensurate with the displayed weight

#### 2) Analog Voltage Output Adjustment (HF20-01)

- ① Default is : 0V output for Zero, 10V output for Max Capacity.
- ② If there is a gap in value caused by distance or environment, the way to adjust is as following ③.
- ③ How to adjust Analog Output
  - When the weight is zero but output is not 0V, You can adjust the gap on HF21
  - When the weight is Max Capacity but output is not 10V, You can adjust the gap on HF22

#### ※ How to select Analog Output (Iout or Vout)

- (1) Switch Iout or Vout through a deep switch installed on option cards.
- (2) Select Analog Output option on HF20 and save the setting value.



## 6-4. Parallel interface

### 6-4-1. BCD IN interface (Part Number External Input card) : OP-07

BCD IN Interface is to enter part number of indicator from external equipment such as PC.

#### 1) Connector Pin

Pin No.	Contents	Pin No	Contents
1	IN 1	14	IN 2
2	IN 3	15	IN 4
3	IN 5	16	IN 6
4	IN 7	17	IN 8
5	IN COM	18	
6		19	GND
7	DC12V 50mA	20	
8		21	
9		22	
10		23	
11		24	
12		25	
13			

#### 2) Connector specification : D-type 25p(Female)

#### 3) Dry contact (Zero voltage point) for Input signal

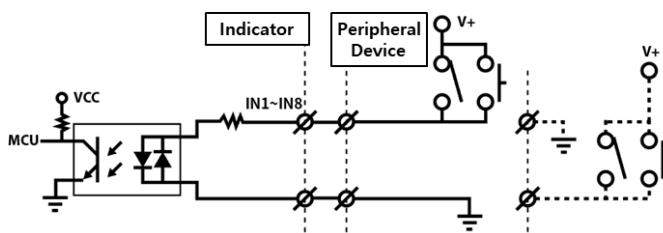

- PLC connection : Power No.7 (DC12V) and No.19(GND).

- Switch connection : Short No. 5 and No. 19, and use Pin No. 7 as INCOM terminal.

### 6-4-2. BCD OUT interface : OP-08

BCD OUT parallel interface is output current weight as BCD code. This interface can be connected with PC, PL, external display or ETC.

#### 1) Connector pin

Pin No.	Contents	Pin No	Contents
1	GND	19	1x10 <sup>0</sup>
2	2x10 <sup>0</sup>	20	4x10 <sup>0</sup>
3	8x10 <sup>0</sup>	21	1x10 <sup>0</sup>
4	2x10 <sup>1</sup>	22	4x10 <sup>0</sup>
5	8x10 <sup>1</sup>	23	1x10 <sup>0</sup>
6	2x10 <sup>2</sup>	24	4x10 <sup>0</sup>
7	8x10 <sup>2</sup>	25	1x10 <sup>0</sup>
8	2x10 <sup>3</sup>	26	4x10 <sup>0</sup>
9	8x10 <sup>3</sup>	27	1x10 <sup>0</sup>
10	2x10 <sup>4</sup>	28	4x10 <sup>0</sup>
11	8x10 <sup>4</sup>	29	1x10 <sup>0</sup>
12	2x10 <sup>5</sup>	30	4x10 <sup>0</sup>
13	8x10 <sup>5</sup>	31	NET/GROSS
14	GND	32	GND
15	Hold	33	Division 0.000
16	Division 0.00	34	Division 0.0
17	Polarity	35	BUSY
18	-	36	O.L

#### 2) Connector specification : Champ 36(FEMALE)

#### 3) BCD OUT output specification : Open-collector output

4) Hold Input has to be connected as open collector output and dry contact output. When Hold is input, BCD-OUT value will be hold.

#### 5) BCD out time chart

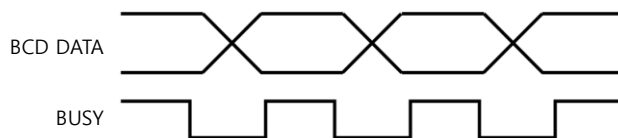

6) Signal logic

	Factory default	Contents	Remark
BDC data	Positive	Positive Negative	Select by the switch on the BCD OUT PCB.
Polarity	When it is “-“, “H” is output	When “-“ is output, open ”H” will be output.	
O.L output	When it is “OL”, “H” is output.	When it is Over-load, open “H” will be output.	
Busy	When it is “Busy”, “H” is output.	If converting of BCD OUT value is completed, “busy” signal is keeping as H. Then it is changed to “L” before starting BCD converting.	
Hold	When it is BCD data “hold”, “L” is output.	If you want BCD data to be “hold”, input signal will be input. (Contact close)	

7) If you want BCD out card as TTL level or voltage source output, please contact to SEWHA CNM Co., Ltd. (Customized product)

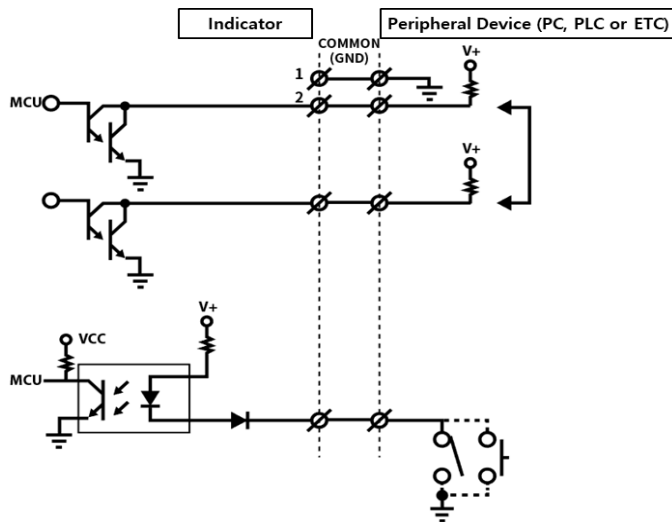

## 6-5. Data Storage Device (SD memory card)

### 6-5-1. Data Storage Device (SD memory card) : OP-09

Data storage device saves the weight data according to F102 setting.



SD memory card has to be installed in Option 2 location.

#### 1) Weighing Data Format (File name: N + Creation date)(ex : N160114)

Save data on SD memory card according to F102 setting.

DATE	TIME	ID	PART	SERIAL	DRIB	BURK	FREE FALL	TARGET
2016-01-01	12:18:04	1	1	1	10	10	10	10
2016-01-01	12:18:10	1	1	2	10	11	12	10
2016-01-01	12:18:10	1	1	3	12	15	13	15

#### 2) Sub-total weighing data format (File name: S + Creation date)(ex : S160114)

Save Sub-total weight data on SD memory card when input "Print Sub-total"

DATE	TIME	ID	PART	SUB TOTAL COUNT	SUB TOTAL WEIGHT	UNIT
2016-01-01	12:00:30	1	1	10	6000	kg
2016-01-01	12:00:30	1	2	10	5000	kg

#### 3) Sub-total1 weighing data format (File name: SA + Creation date)(ex : S160114)

When input Print Sub-total, save sub-total weight on SD memory card.

DATE	TIME	ID	PART	A_SUB COUNT	DRIB	BURK	FREE FALL	TARGET	A_SUB WEIGHT	UNIT
2016-01-01	12:00:30	1	1	10	11	12	13	14	6000	kg
2016-01-01	12:00:30	1	2	10	18	17	16	15	5000	kg

4) Total weighing data format (File name: T + Creation date)(ex : T160114)

DATE	TIME	TOTAL COUNT	TOTAL WEIGHT	UNIT
2016-01-01	12:27:30	17	4620	kg

ID	PART	SUB COUNT	SP1	SP2	SP3	SP4	SUB WEIGHT	UNIT
1	1	5	1	2	1	1	1207	kg
1	2	8	2	3	5	2	2383	kg
1	3	2	4	4	5	4	506	kg
1	4	2	5	5	7	1	524	kg

5) SD Memory Specification

Memory	Model	Form factor	Class
8G	SanDisk SDHC memory card 8G	SDHC	4



- Recommend you to use the specified SD memory card.
- Back up the files and format the SD memory regularly since USB Memory has capacity.
- Right-click on the removable disk drive, run the format, select FAT32 in the file system, and press Start.

## 6-6. Option card combination

Maximum 2EA of option card can be installed. Below combination is available.

Classification	OP-01	OP-02 OP-03	OP-04	OP-05 OP-06	OP-07	OP-08	OP-09
	Serial (RS232)	Serial (RS422, RS485)	Ether- net	Analog out	BCD IN	BCD OUT	SD memory card
Serial RS232	X	X	0	0	0	0	0
Serial RS422, RS485	X	X	0	0	0	0	0
Ethernet	0	0	X	0	0	X	0
Analog out	0	0	0	X	0	0	0
BCD IN	0	0	0	0	X	0	0
BCD OUT	0	0	X	0	0	X	0
SD memory card	0	0	0	0	0	0	X

## 7. Communication Data Format

### 7-1. Stream Mode

7-1-1 Format 1 (excluding ID number) – 18 byte

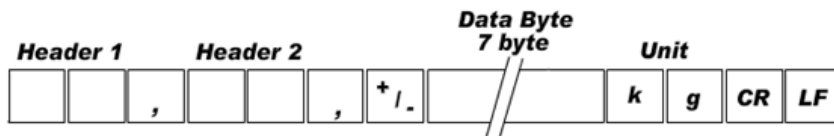

Classification	Contents
Header1 (2Byte)	OL : Overloaded ST : Stable US : Unstable
Header2 (2Byte)	NT : NET-WEIGHT GS : GROSS-WEIGHT
Sign (1Byte)	Mark
Weight Data (7Byte)	Current weight
UNIT (2Byte)	kg- <input type="text"/> k <input type="text"/> g g- <input type="text"/> <input type="text"/> g ton- <input type="text"/> <input type="text"/> t
CR (1byte)	Carriage Return
LF (1byte)	Line Feed
Example	ASCII : ST,NT,+0000.00kg CR LF HEX : 53h 54h 2Ch 4Eh 54h 2Ch 2Bh 30h 30h 30h 30h 2Eh 30h 30h 6Bh 67h 0Dh 0Ah

7-1-2. Format 2 (including ID number) – 21 byte

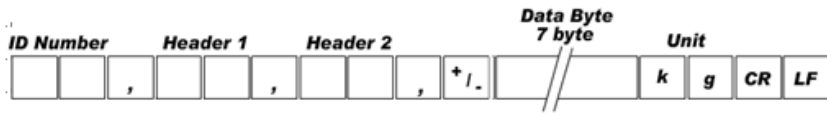

Classification	Contents						
ID Number (2Byte)	ID number						
Header1 (2Byte)	OL : Overloaded ST : Stable US : Unstable						
Header2 (2Byte)	NT : NET-WEIGHT GS : GROSS-WEIGHT						
Sign (1Btye)	Mark						
Weight Data (7Byte)	Sign						
UNIT (2Byte)	kg - <table border="1" style="display: inline-table; vertical-align: middle;"><tr><td>k</td><td>g</td></tr></table> g - <table border="1" style="display: inline-table; vertical-align: middle;"><tr><td> </td><td>g</td></tr></table> ton - <table border="1" style="display: inline-table; vertical-align: middle;"><tr><td> </td><td>t</td></tr></table>	k	g		g		t
k	g						
	g						
	t						
CR (1byte)	Carriage Return						
LF (1byte)	Line Feed						
Example	ASCII : 01,ST,NT,+0000.00kg CR LF HEX : 30h 31h 2Ch 53h 54h 2Ch 4Eh 54h 2Ch 2Bh 30h 30h 30h 30h 2Eh 30h 30h 6Bh 67h 0Dh 0Ah						



7-1-3. Format 3 (including ID number) – 17 byte

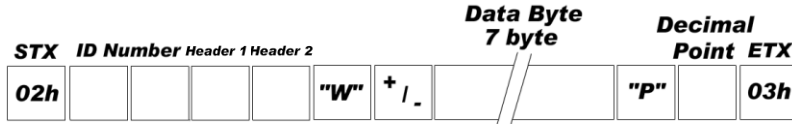

Classification	Contents
STX (1Byte)	Start of Text
ID Number (2Byte)	
Header1 (1Byte)	O : Overloaded S : Stable U : Unstable
Header2 (1Byte)	N : NET-WEIGHT G : GROSS-WEIGHT
"W" (1Byte)	Current weight separator
Sign (1Byte)	Mark
Weight Data (7Byte)	Current weight
"P" (1Byte)	Decimal point separator
Decimal Point (1Byte)	
ETX (1Byte)	End of Text
Example	ASCII : STX 01SNW+0000000P2 ETX HEX : 02h 30h 31h 53h 4Eh 57h 2Bh 30h 30h 30h 30h 30h 30h 30h 50h 32h 03h

7-1-4. Format 4 (including ID number) – 22 byte

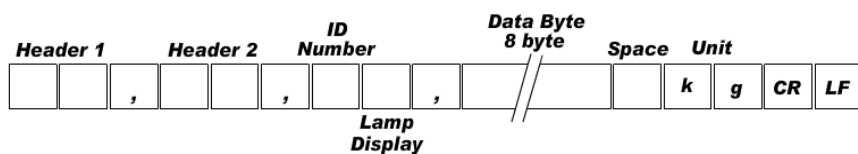

Classification	Contents
Header1 (2Byte)	OL : Overloaded ST : Stable US : Unstable
Header2 (2Byte)	NT : NET-WEIGHT GS : GROSS-WEIGHT
ID Number (1Byte)	ID number
Lamp Display (1Byte)	Lamp status display
Weight Data (8Byte)	Current weight including mark (Mark for minus '-' only)
UNIT (2Byte)	kg : kg g : g t : ton
CR (1byte)	Carriage Return
LF (1byte)	Line Feed
Example	ASCII : ST,NT,?.?_0.12 kg CR LF HEX : 53h 54h 2Ch 4Eh 54h 2Ch 01h E1h 2Ch 20h 20h 20h 20h 30h 2Eh 31h 32h 20h 6Bh 67h 0Dh 0Ah

※ Lamp display

Bit 7	Bit 6	Bit 5	Bit 4	Bit 3	Bit 2	Bit 1	Bit 0
1	Steady	1	Hold	Print	Gross weight	Tare	Zero

7-1-5. Format 5 (Part number, Judged value, for checker mode) – 15 byte

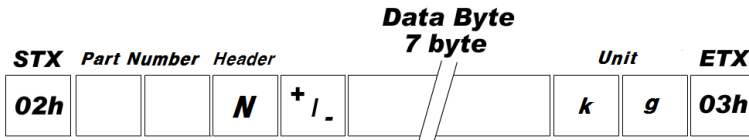

Classification	Contents
STX (1Byte)	Start of Text
Part Number (2Byte)	P/N
Header1 (1Byte)	N : No judged value U : Underweight P : Pass O : Overweight
Sign (1Byte)	Mark
Weight Data (7Byte)	Current weight
UNIT (2Byte)	kg : kg g : g t : ton
ETX (1Byte)	End of Text
Example	ASCII : STX 01N+0000.00kg ETX HEX : 02h 30h 31h 4Eh 2Bh 30h 30h 30h 30h 2Eh 30h 30h 6Bh 67h 03h

## 7-2. Command mode

Command judgement processes data 06h (ACK), 15h (NAK) and Error Code which starts with 02h(STX) and ends with 03h(ETX).

### 7-2-1. Read mode

Current Weight (Displayed Weight)		
Transmit	Format : STX(1) ID(2) RCWT(4) ETX(1) ASCII : STX 01RCWT ETX HEX : 02h 30h 31h 52h 43h 57h 54h 03h	8 Byte
Respond	Format : STX(1) ID(2) RCWT(4) State1(1) State2(1) P(1) Decimal point(1) Mark(1) Current weight(6) Unit(2) ETX(1) ASCII : STX 01RCWTSNP2+001234kg ETX HEX : 02h 30h 31h 52h 43h 57h 54h 53h 4Eh 50h 32h 2Bh 30h 30h 31h 32h 33h 34h 6Bh 67h 03h	21 Byte
	State 1: O(Overloaded), S(Stable), U(Unstable) State 2: N(Net Weight), G(Gross Weight)	
Current Weight (Memory)		
Transmit	Format : STX(1) ID(2) RCWD(4) ETX(1) ASCII : STX 01RCWD ETX HEX : 02h 30h 31h 52h 43h 57h 44h 03h	8 Byte
Respond	Format : STX(1) ID(2) RCWD(4) P(1) Decimal point(1) Date(6) Time(6) Part number(2) Weighing count(6) Mark(1) Tare weight(6) Mark(1) Current weight(6) Unit(2) ETX(1) ASCII : STX 01RCWDP217110112303501012345+012345+012345kg ETX HEX : 02h 30h 31h 52h 43h 57h 44h 50h 32h 31h 37h 31h 31h 30h 31h 31h 32h 33h 30h 33h 35h 30h 31h 30h 31h 32h 33h 34h 35h 2Bh 30h 31h 32h 33h 34h 35h 2Bh 30h 31h 32h 33h 34h 35h 6Bh 67h 03h	46 Byte
Sub-total		
Transmit	Format : STX(1) ID(2) RSUB(4) ETX(1) ASCII : STX 01RSUB ETX HEX : 02h 30h 31h 52h 53h 55h 42h 03h	8 Byte
Respond	Format : STX(1) ID(2) RSUB(4) P(1) Decimal Point(1) Part Number(2) Sub- total count(6) Sub-total(10) Unit(2) ETX(1) ASCII : STX 01RSUBP2010123450123456789kg ETX HEX : 02h 30h 31h 52h 53h 55h 42h 50h 32h 30h 31h 30h 31h 32h 33h 34h 35h 30h 31h 32h 33h 34h 35h 36h 37h 38h 39h 6Bh 67h 03h	30 Byte

Total		
Transmit	Format : STX(1) ID(2) RGRD(4) ETX(1) ASCII : STX 01RGRD ETX HEX : 02h 30h 31h 52h 47h 52h 44h 03h	8 byte
Respond	Format : STX(1) ID(2) RGRD(4) P(1) Decimal Point(1) Total Count(6) Total Weight(10) Unit(2) ETX(1) ASCII : STX 01RGRDP20123450123456789kg ETX HEX : 02h 30h 31h 52h 47h 52h 44h 50h 32h 30h 31h 32h 33h 34h 35h 30h 31h 32h 33h 34h 35h 36h 37h 38h 39h 6Bh 67h 03h	28 byte
Sub-total Count		
Transmit	Format : STX(1) ID(2) RSNO(4) ETX(1) ASCII : STX 01RSNO ETX HEX : 02h 30h 31h 52h 53h 4Eh 4Fh 03h	8 Byte
Respond	Format : STX(1) ID(2) RSNO(4) Sub-total Count(6) ETX(1) ASCII : STX 01RSNO012345 ETX HEX : 02h 30h 31h 52h 53h 4Eh 4Fh 30h 31h 32h 33h 34h 35h 03h	14 Byte
Weighing Finish Value		
Transmit	Format : STX(1) ID(2) RFIN(4) ETX(1) ASCII : STX 01RFIN ETX HEX : 02h 30h 31h 52h 46h 49h 4Eh 03h	8 Byte
Respond	Format : STX(1) ID(2) RFIN(4) P(1) Decimal Point(1) Mark(1) Weighing Finish Value(6) ETX(1) ASCII : STX 01RFINP2+012345 ETX HEX : 02h 30h 31h 52h 46h 49h 4Eh 50h 32h 2Bh 30h 31h 32h 33h 34h 35h 03h	17 Byte
Time		
Transmit	Format : STX(1) ID(2) RTIM(4) ETX(1) ASCII : STX 01RTIM ETX HEX : 02h 30h 31h 52h 54h 49h 4Dh 03h	8 Byte
Respond	Format : STX(1) ID(2) RTIM(4) Time(6) ETX(1) ASCII : STX 01RTIM123035 ETX HEX : 02h 30h 31h 52h 54h 49h 4Dh 31h 32h 33h 30h 33h 35h 03h	14 Byte
Date		
Transmit	Format : STX(1) ID(2) RDAT(4) ETX(1) ASCII : STX 01RDAT ETX HEX : 02h 30h 31h 52h 44h 41h 54h 03h	8 Byte
Respond	Format : STX(1) ID(2) RDAT(4) Date(6) ETX(1) ASCII : STX 01RDAT171101 ETX HEX : 02h 30h 31h 52h 44h 41h 54h 31h 37h 31h 31h 30h 31h 03h	14 Byte

Tare Weight		
Transmit	Format : STX(1) ID(2) RTAR(4) ETX(1) ASCII : STX 01RTAR ETX HEX : 02h 30h 31h 52h 54h 41h 52h 03h	8 Byte
Respond	Format : STX(1) ID(2) RTAR(4) P(1) Decimal Point(1) Mark(1) Tare Weight(6) ETX(1) ASCII : STX 01RTARP2+012345 ETX HEX : 02h 30h 31h 52h 54h 41h 52h 50h 32h 2Bh 30h 31h 32h 33h 34h 35h 03h	17 Byte
SP1 (Setting Value)		
Transmit	Format : STX(1) ID(2) RSP1(4) ETX(1) ASCII : STX 01RSP1 ETX HEX : 02h 30h 31h 52h 53h 50h 31h 03h	8 Byte
Respond	Format : STX(1) ID(2) RSP1(4) P(1) Decimal Point(1) SP1(6) ETX(1) ASCII : STX 01RSP1P2012345 ETX HEX : 02h 30h 31h 52h 53h 50h 31h 50h 32h 30h 31h 32h 33h 34h 35h 03h	16 Byte
SP2 (1-Stage)		
Transmit	Format : STX(1) ID(2) RSP2(4) ETX(1) ASCII : STX 01RSP2 ETX HEX : 02h 30h 31h 52h 53h 50h 32h 03h	8 Byte
Respond	Format : STX(1) ID(2) RSP2(4) P(1) Decimal Point(1) SP2(6) ETX(1) ASCII : STX 01RSP2P2012345 ETX HEX : 02h 30h 31h 52h 53h 50h 32h 50h 32h 30h 31h 32h 33h 34h 35h 03h	16 Byte
SP3 (2-Stage)		
Transmit	Format : STX(1) ID(2) RSP3(4) ETX(1) ASCII : STX 01RSP3 ETX HEX : 02h 30h 31h 52h 53h 50h 33h 03h	8 Byte
Respond	Format : STX(1) ID(2) RSP3(4) P(1) Decimal Point(1) SP3(6) ETX(1) ASCII : STX 01RSP3P2012345 ETX HEX : 02h 30h 31h 52h 53h 50h 33h 50h 32h 30h 31h 32h 33h 34h 35h 03h	16 Byte
SP4 (Free Fall)		
Transmit	Format : STX(1) ID(2) RSP4(4) ETX(1) ASCII : STX 01RSP4 ETX HEX : 02h 30h 31h 52h 53h 50h 34h 03h	8 Byte
Respond	Format : STX(1) ID(2) RSP4(4) P(1) Decimal Point(1) SP4(6) ETX(1) ASCII : STX 01RSP4P2012345 ETX HEX : 02h 30h 31h 52h 53h 50h 34h 50h 32h 30h 31h 32h 33h 34h 35h 03h	16 Byte

SP5 (Charge Free Fall)		
Transmit	Format : STX(1) ID(2) RSP5(4) ETX(1) ASCII : STX 01RSP5 ETX HEX : 02h 30h 31h 52h 53h 50h 35h 03h	8 Byte
Respond	Format : STX(1) ID(2) RSP5(4) P(1) Decimal Point(1) SP5(6) ETX(1) ASCII : STX 01RSP5P2012345 ETX HEX : 02h 30h 31h 52h 53h 50h 35h 50h 32h 30h 31h 32h 33h 34h 35h 03h	16 Byte
SP6 (Discharge Free fall)		
Transmit	Format : STX(1) ID(2) RSP6(4) ETX(1) ASCII : STX 01RSP6 ETX HEX : 02h 30h 31h 52h 53h 50h 36h 03h	8 Byte
Respond	Format : STX(1) ID(2) RSP6(4) P(1) Decimal Point(1) SP6(6) ETX(1) ASCII : STX 01RSP6P2012345 ETX HEX : 02h 30h 31h 52h 53h 50h 36h 50h 32h 30h 31h 32h 33h 34h 35h 03h	16 Byte
Current Weight, External Input, Relay Out		
Transmit	Format : STX(1) ID(2) RWRS(4) ETX(1) ASCII : STX 01RWRS ETX HEX : 02h 30h 31h 52h 57h 52h 53h 03h	8 Byte
Respond	Format : STX(1) ID(2) RWRS(4) P(1) Decimal Point(1) Mark(1) Current Weight(6) External Input(6) Relay Out(7) ETX(1) ASCII : STX 01RWRS P2+012345000000000001 ETX HEX : 02h 30h 31h 52h 57h 52h 53h 50h 32h 2Bh 30h 31h 32h 33h 34h 35h 30h 30h 30h 30h 30h 30h 30h 30h 30h 30h 30h 30h 31h 03h	30 Byte
Current Part Number		
Transmit	Format : STX(1) ID(2) RPNO(4) ETX(1) ASCII : STX 01RPNO ETX HEX : 02h 30h 31h 52h 50h 4Eh 4Fh 03h	8 Byte
Respond	Format : STX(1) ID(2) RPNO(4) Part Number(2) ETX(1) ASCII : STX 01RPNO01 ETX HEX : 02h 30h 31h 52h 50h 4Eh 4Fh 30h 31h 03h	10 Byte

SP1, SP2, SP3, SP4, SP5, SP6		
Transmit	Format : STX(1) ID(2) RFTT(4) ETX(1) ASCII : STX 01RFTT ETX HEX : 02h 30h 31h 52h 46h 54h 54h 03h	8 Byte
Respond	Format : STX(1) ID(2) RFTT(4) P(1) Decimal Point(1) SP1(6) SP2(6) SP3(6) SP4(6) SP5(6) SP6(6) ETX(1) ASCII : STX 01RFTTP2012345012345012345012345012345 ETX HEX : 02h 30h 31h 52h 46h 54h 54h 50h 32h 30h 31h 32h 33h 34h 35h 30h 31h 32h 33h 34h 35h 30h 31h 32h 33h 34h 35h 30h 31h 32h 33h 34h 35h 30h 31h 32h 33h 34h 35h 30h 31h 32h 33h 34h 35h 03h	46 Byte



### 7-2-2. Write mode

-Transmit(normal): STX + ID(2Byte) + ACK + ERROR\_CORD (1Byte) + ETX

-Transmit(error): STX + ID(2Byte) + NAK + ERROR\_CORD (1Byte) + ETX

Error code	
0 : Normality	1 : Check-Sum Error
2 : Received Data length Error	3 : Received Data range Error
4 : Write prohibit error (It is not allowed during run process)	

Zero Setting			
Transmit	Format : STX(1) ID(2) WZER(4) ETX(1) ASCII : STX 01WZER ETX HEX : 02h 30h 31h 57h 5Ah 45h 52h 03h		8 Byte
Respond	Normal	Format : STX(1) ID(2) ACK(1) ERROR(1) ETX(1) ASCII : STX 01 ACK 0 ETX HEX : 02h 30h 31h 06h 30h 03h	6 Byte
	Error	Format : STX(1) ID(2) NAK(1) ERROR(1) ETX(1) ASCII : STX 01 NAK 2 ETX HEX : 02h 30h 31h 15h 32h 03h	
Tare Setting			
Transmit	Format : STX(1) ID(2) WTAR(4) ETX(1) ASCII : STX 01WTAR ETX HEX : 02h 30h 31h 57h 54h 41h 52h 03h		8 Byte
Respond	Normal	Format : STX(1) ID(2) ACK(1) ERROR(1) ETX(1) ASCII : STX 01 ACK 0 ETX HEX : 02h 30h 31h 06h 30h 03h	6 Byte
	Error	Format : STX(1) ID(2) NAK(1) ERROR(1) ETX(1) ASCII : STX 01 NAK 2 ETX HEX : 02h 30h 31h 15h 32h 03h	

Tare Reset			
Transmit	Format : STX(1) ID(2) WTRS(4) ETX(1) ASCII : STX 01WTRS ETX HEX : 02h 30h 31h 57h 54h 52h 53h 03h		8 Byte
Respond	Normal	Format : STX(1) ID(2) ACK(1) ERROR(1) ETX(1) ASCII : STX 01 ACK 0 ETX HEX : 02h 30h 31h 06h 30h 03h	6 Byte
	Error	Format : STX(1) ID(2) NAK(1) ERROR(1) ETX(1) ASCII : STX 01 NAK 2 ETX HEX : 02h 30h 31h 15h 32h 03h	
Print			
Transmit	Format : STX(1) ID(2) WPRT(4) ETX(1) ASCII : STX 01WPRT ETX HEX : 02h 30h 31h 57h 50h 52h 54h 03h		8 Byte
Respond	Normal	Format : STX(1) ID(2) ACK(1) ERROR(1) ETX(1) ASCII : STX 01 ACK 0 ETX HEX : 02h 30h 31h 06h 30h 03h	6 Byte
	Error	Format : STX(1) ID(2) NAK(1) ERROR(1) ETX(1) ASCII : STX 01 NAK 2 ETX HEX : 02h 30h 31h 15h 32h 03h	
Print Sub-total			
Transmit	Format : STX(1) ID(2) WSPR(4) ETX(1) ASCII : STX 01WSPR ETX HEX : 02h 30h 31h 57h 53h 50h 52h 03h		8 Byte
Respond	Normal	Format : STX(1) ID(2) ACK(1) ERROR(1) ETX(1) ASCII : STX 01 ACK 0 ETX HEX : 02h 30h 31h 06h 30h 03h	6 Byte
	Error	Format : STX(1) ID(2) NAK(1) ERROR(1) ETX(1) ASCII : STX 01 NAK 2 ETX HEX : 02h 30h 31h 15h 32h 03h	

Print Total			
Transmit	Format : STX(1) ID(2) WGPR(4) ETX(1) ASCII : STX 01WGPR ETX HEX : 02h 30h 31h 57h 47h 50h 52h 03h		8 Byte
Respond	Normal	Format : STX(1) ID(2) ACK(1) ERROR(1) ETX(1) ASCII : STX 01 ACK 0 ETX HEX : 02h 30h 31h 06h 30h 03h	6 Byte
	Error	Format : STX(1) ID(2) NAK(1) ERROR(1) ETX(1) ASCII : STX 01 NAK 2 ETX HEX : 02h 30h 31h 15h 32h 03h	
Delete Sub-total			
Transmit	Format : STX(1) ID(2) WSTC(4) ETX(1) ASCII : STX 01WSTC ETX HEX : 02h 30h 31h 57h 53h 54h 43h 03h		8 Byte
Respond	Normal	Format : STX(1) ID(2) ACK(1) ERROR(1) ETX(1) ASCII : STX 01 ACK 0 ETX HEX : 02h 30h 31h 06h 30h 03h	6 Byte
	Error	Format : STX(1) ID(2) NAK(1) ERROR(1) ETX(1) ASCII : STX 01 NAK 2 ETX HEX : 02h 30h 31h 15h 32h 03h	
Delete Total			
Transmit	Format : STX(1) ID(2) WGTC(4) ETX(1) ASCII : STX 01WGTC ETX HEX : 02h 30h 31h 57h 47h 54h 43h 03h		8 Byte
Respond	Normal	Format : STX(1) ID(2) ACK(1) ERROR(1) ETX(1) ASCII : STX 01 ACK 0 ETX HEX : 02h 30h 31h 06h 30h 03h	6 Byte
	Error	Format : STX(1) ID(2) NAK(1) ERROR(1) ETX(1) ASCII : STX 01 NAK 2 ETX HEX : 02h 30h 31h 15h 32h 03h	
Run			
Transmit	Format : STX(1) ID(2) WSTR(4) ETX(1) ASCII : STX 01WSTR ETX HEX : 02h 30h 31h 57h 53h 54h 52h 03h		8 Byte
Respond	Normal	Format : STX(1) ID(2) ACK(1) ERROR(1) ETX(1) ASCII : STX 01 ACK 0 ETX HEX : 02h 30h 31h 06h 30h 03h	6 Byte
	Error	Format : STX(1) ID(2) NAK(1) ERROR(1) ETX(1) ASCII : STX 01 NAK 2 ETX HEX : 02h 30h 31h 15h 32h 03h	

Stop			
Transmit	Format : STX(1) ID(2) WSTP(4) ETX(1) ASCII : STX 01WSTP ETX HEX : 02h 30h 31h 57h 53h 54h 50h 03h		8 Byte
Respond	Normal	Format : STX(1) ID(2) ACK(1) ERROR(1) ETX(1) ASCII : STX 01 ACK 0 ETX HEX : 02h 30h 31h 06h 30h 03h	6 Byte
	Error	Format : STX(1) ID(2) NAK(1) ERROR(1) ETX(1) ASCII : STX 01 NAK 2 ETX HEX : 02h 30h 31h 15h 32h 03h	
Time Setting			
Transmit	Format : STX(1) ID(2) WTIM(4) TIME(6) ETX(1) ASCII : STX 01WTIM123035 ETX HEX : 02h 30h 31h 57h 54h 49h 4Dh 31h 32h 33h 30h 33h 35h 03h		14 Byte
Respond	Normal	Format : STX(1) ID(2) ACK(1) ERROR(1) ETX(1) ASCII : STX 01 ACK 0 ETX HEX : 02h 30h 31h 06h 30h 03h	6 Byte
	Error	Format : STX(1) ID(2) NAK(1) ERROR(1) ETX(1) ASCII : STX 01 NAK 2 ETX HEX : 02h 30h 31h 15h 32h 03h	
Date Setting			
Transmit	Format : STX(1) ID(2) WDAT(4) DATE(6) ETX(1) ASCII : STX 01WDAT171101 ETX HEX : 02h 30h 31h 57h 44h 41h 54h 31h 37h 31h 31h 30h 31h 03h		14 Byte
Respond	Normal	Format : STX(1) ID(2) ACK(1) ERROR(1) ETX(1) ASCII : STX 01 ACK 0 ETX HEX : 02h 30h 31h 06h 30h 03h	6 Byte
	Error	Format : STX(1) ID(2) NAK(1) ERROR(1) ETX(1) ASCII : STX 01 NAK 2 ETX HEX : 02h 30h 31h 15h 32h 03h	

SP1 Setting (Setting Value)			
Transmit	Format : STX(1) ID(2) WSP1(4) SP1(6) ETX(1) ASCII : STX 01WSP1012345 ETX HEX : 02h 30h 31h 57h 53h 50h 31h 30h 31h 32h 33h 34h 35h 03h		14 Byte
Respond	Normal	Format : STX(1) ID(2) ACK(1) ERROR(1) ETX(1) ASCII : STX 01 ACK 0 ETX HEX : 02h 30h 31h 06h 30h 03h	6 Byte
	Error	Format : STX(1) ID(2) NAK(1) ERROR(1) ETX(1) ASCII : STX 01 NAK 2 ETX HEX : 02h 30h 31h 15h 32h 03h	
SP2 Setting (1-Stage)			
Transmit	Format : STX(1) ID(2) WSP2(4) SP2(6) ETX(1) ASCII : STX 01WSP2012345 ETX HEX : 02h 30h 31h 57h 53h 50h 32h 30h 31h 32h 33h 34h 35h 03h		14 Byte
Respond	Normal	Format : STX(1) ID(2) ACK(1) ERROR(1) ETX(1) ASCII : STX 01 ACK 0 ETX HEX : 02h 30h 31h 06h 30h 03h	6 Byte
	Error	Format : STX(1) ID(2) NAK(1) ERROR(1) ETX(1) ASCII : STX 01 NAK 2 ETX HEX : 02h 30h 31h 15h 32h 03h	
SP3 Setting (2-Stage)			
Transmit	Format : STX(1) ID(2) WSP3(4) SP3 (6) ETX(1) ASCII : STX 01WSP3012345 ETX HEX : 02h 30h 31h 57h 53h 50h 33h 30h 31h 32h 33h 34h 35h 03h		14 Byte
Respond	Normal	Format : STX(1) ID(2) ACK(1) ERROR(1) ETX(1) ASCII : STX 01 ACK 0 ETX HEX : 02h 30h 31h 06h 30h 03h	6 Byte
	Error	Format : STX(1) ID(2) NAK(1) ERROR(1) ETX(1) ASCII : STX 01 NAK 2 ETX HEX : 02h 30h 31h 15h 32h 03h	

SP4 Setting (Free Fall)			
Transmit	Format : STX(1) ID(2) WSP4(4) SP4 (6) ETX(1) ASCII : STX 01WSP4012345 ETX HEX : 02h 30h 31h 57h 53h 50h 34h 30h 31h 32h 33h 34h 35h 03h		14 Byte
Respond	Normal	Format : STX(1) ID(2) ACK(1) ERROR(1) ETX(1) ASCII : STX 01 ACK 0 ETX HEX : 02h 30h 31h 06h 30h 03h	6 Byte
	Error	Format : STX(1) ID(2) NAK(1) ERROR(1) ETX(1) ASCII : STX 01 NAK 2 ETX HEX : 02h 30h 31h 15h 32h 03h	
SP5 Setting (Charge Free Fall)			
Transmit	Format : STX(1) ID(2) WSP5(4) SP5(6) ETX(1) ASCII : STX 01WSP5012345 ETX HEX : 02h 30h 31h 57h 53h 50h 35h 30h 31h 32h 33h 34h 35h 03h		14 Byte
Respond	Normal	Format : STX(1) ID(2) ACK(1) ERROR(1) ETX(1) ASCII : STX 01 ACK 0 ETX HEX : 02h 30h 31h 06h 30h 03h	6 Byte
	Error	Format : STX(1) ID(2) NAK(1) ERROR(1) ETX(1) ASCII : STX 01 NAK 2 ETX HEX : 02h 30h 31h 15h 32h 03h	
SP6 Setting (Discharge Free Fall)			
Transmit	Format : STX(1) ID(2) WSP6(4) SP6설정값(6) ETX(1) ASCII : STX 01WSP6012345 ETX HEX : 02h 30h 31h 57h 53h 50h 36h 30h 31h 32h 33h 34h 35h 03h		14 Byte
Respond	Normal	Format : STX(1) ID(2) ACK(1) ERROR(1) ETX(1) ASCII : STX 01 ACK 0 ETX HEX : 02h 30h 31h 06h 30h 03h	6 Byte
	Error	Format : STX(1) ID(2) NAK(1) ERROR(1) ETX(1) ASCII : STX 01 NAK 2 ETX HEX : 02h 30h 31h 15h 32h 03h	

Part Number Change			
Transmit	Format : STX(1) ID(2) WPNO(4) Part Number(2) ETX(1) ASCII : STX 01WPNO10 ETX HEX : 02h 30h 31h 57h 50h 4Eh 4Fh 31h 30h 03h		10 Byte
Respond	Normal	Format : STX(1) ID(2) ACK(1) ERROR(1) ETX(1) ASCII : STX 01 ACK 0 ETX HEX : 02h 30h 31h 06h 30h 03h	6 Byte
	Error	Format : STX(1) ID(2) NAK(1) ERROR(1) ETX(1) ASCII : STX 01 NAK 2 ETX HEX : 02h 30h 31h 15h 32h 03h	
SP1, SP2, SP3, SP4, SP5, SP6 Setting			
Transmit	Format : STX(1) ID(2) WFTD(4) SP1(6) SP2(6) SP3(6) SP4(6) SP5(6) SP6(6) ETX(1) ASCII : STX 01WFTD012345012345012345012345012345012345 ETX HEX : 02h 30h 31h 57h 46h 54h 44h 30h 31h 32h 33h 34h 35h 30h 31h 32h 33h 34h 35h 30h 31h 32h 33h 34h 35h 30h 31h 32h 33h 34h 35h 30h 31h 32h 33h 34h 35h 30h 31h 32h 33h 34h 35h 03h		44 Byte
Respond	Normal	Format : STX(1) ID(2) ACK(1) ERROR(1) ETX(1) ASCII : STX 01 ACK 0 ETX HEX : 02h 30h 31h 06h 30h 03h	6 Byte
	Error	Format : STX(1) ID(2) NAK(1) ERROR(1) ETX(1) ASCII : STX 01 NAK 2 ETX HEX : 02h 30h 31h 15h 32h 03h	

## 7-3. Command mode (compatible with SI4410)

### 7-3-1. Read command

Current Weight (Displayed Weight)		
Transmit	Format : STX(1) ID(2) RCWT(4) ETX(1) ASCII : STX 01RCWT ETX HEX : 02h 30h 31h 52h 43h 57h 54h 03h	8 Byte
Respond	Format : STX(1) ID(2) RCWT(4) State1(2) State2(2) Sign(1) Current weight(7) Unit(2) ETX(1) ASCII : STX 01RCWTST,NT,+0123.45kg ETX HEX : 02h 30h 31h 52h 43h 57h 54h 53h 54h 2Ch 4Eh 54h 2Ch 2Bh 30h 31h 32h 33h 2Eh 34h 35h 6Bh 67h 03h	24 Byte
	State 1: OL(Current weight is over than max capacity weight), ST(Stable weight), US(Unstable weight) State 2: NT(Net weight), GS(Gross weight)	
Current Weight (Memory)		
Transmit	Format : STX(1) ID(2) RCWD(4) ETX(1) ASCII : STX 01RCWD ETX HEX : 02h 30h 31h 52h 43h 57h 44h 03h	8 Byte
Respond	Format : STX(1) ID(2) RCWD(4) Date(6) Time(6) Part number(2) Weighing count(6) Tare weight(7) Sign(1) Current weight(7) Unit(2) ETX(1) ASCII : STX 01RCWD171101123035010123450123.45+0123.45kg ETX HEX : 02h 30h 31h 52h 43h 57h 44h 31h 37h 31h 31h 30h 31h 31h 32h 33h 30h 33h 35h 30h 31h 30h 31h 32h 33h 34h 35h 30h 31h 32h 33h 2Eh 34h 35h 2Bh 30h 31h 32h 33h 2Eh 34h 35h 6Bh 67h 03h	45 Byte



Sub-total		
Transmit	Format : STX(1) ID(2) RSUB(4) ETX(1) ASCII : STX 01RSUB ETX HEX : 02h 30h 31h 52h 53h 55h 42h 03h	8 Byte
Respond	Format : STX(1) ID(2) RSUB(4) Part number(2) Sub-total weighing count(6) Sub-total weight(11) Unit(2) ETX(1) ASCII : STX 01RSUB0101234501234567.89kg ETX HEX : 02h 30h 31h 52h 53h 55h 42h 30h 31h 30h 31h 32h 33h 34h 35h 30h 31h 32h 33h 34h 35h 36h 37h 2Eh 38h 39h 6Bh 67h 03h	29 Byte
Sub-total Count		
Transmit	Format : STX(1) ID(2) RSNO(4) ETX(1) ASCII : STX 01RSNO ETX HEX : 02h 30h 31h 52h 53h 4Eh 4Fh 03h	8 Byte
Respond	Format : STX(1) ID(2) RSNO(4) Sub-total weighing count(6) ETX(1) ASCII : STX 01RSNO012345 ETX HEX : 02h 30h 31h 52h 53h 4Eh 4Fh 30h 31h 32h 33h 34h 35h 03h	14 Byte
Total		
Transmit	Format : STX(1) ID(2) RGRD(4) ETX(1) ASCII : STX 01RGRD ETX HEX : 02h 30h 31h 52h 47h 52h 44h 03h	8 byte
Respond	Format : STX(1) ID(2) RGRD(4) Part number(2) Total weighing count(6) Total accumulated weight (11) Unit(2) ETX(1) ASCII : STX 01RGRD0101234501234567.89kg ETX HEX : 02h 30h 31h 52h 47h 52h 44h 30h 31h 30h 31h 32h 33h 34h 35h 30h 31h 32h 33h 34h 35h 36h 37h 2Eh 38h 39h 6Bh 67h 03h	29 byte
Time		
Transmit	Format : STX(1) ID(2) RTIM(4) ETX(1) ASCII : STX 01RTIM ETX HEX : 02h 30h 31h 52h 54h 49h 4Dh 03h	8 Byte
Respond	Format : STX(1) ID(2) RTIM(4) Current time(6) ETX(1) ASCII : STX 01RTIM123035 ETX HEX : 02h 30h 31h 52h 54h 49h 4Dh 31h 32h 33h 30h 33h 35h 03h	14 Byte

Date		
Transmit	Format : STX(1) ID(2) RDAT(4) ETX(1) ASCII : STX 01RDAT ETX HEX : 02h 30h 31h 52h 44h 41h 54h 03h	8 Byte
Respond	Format : STX(1) ID(2) RDAT(4) Current date(6) ETX(1) ASCII : STX 01RDAT171101 ETX HEX : 02h 30h 31h 52h 44h 41h 54h 31h 37h 31h 30h 31h 03h	14 Byte
Tare Weight		
Transmit	Format : STX(1) ID(2) RTAR(4) ETX(1) ASCII : STX 01RTAR ETX HEX : 02h 30h 31h 52h 54h 41h 52h 03h	8 Byte
Respond	Format : STX(1) ID(2) RTAR(4) Tare weight(7) ETX(1) ASCII : STX 01RTAR0123.45 ETX HEX : 02h 30h 31h 52h 54h 41h 52h 30h 31h 32h 33h 2Eh 34h 35h 03h	15 Byte
SP1 (Setting Value)		
Transmit	Format : STX(1) ID(2) RFIL(4) ETX(1) ASCII : STX 01RFIL ETX HEX : 02h 30h 31h 52h 46h 49h 4Ch 03h	8 Byte
Respond	Format : STX(1) ID(2) RFIL(4) SP1(7) ETX(1) ASCII : STX 01RFIL0123.45 ETX HEX : 02h 30h 31h 52h 46h 49h 4Ch 30h 31h 32h 33h 2Eh 34h 35h 03h	15 Byte
SP2 (1-Stage)		
Transmit	Format : STX(1) ID(2) RPR1(4) ETX(1) ASCII : STX 01RPR1 ETX HEX : 02h 30h 31h 52h 50h 52h 31h 03h	8 Byte
Respond	Format : STX(1) ID(2) RPR1(4) SP2(7) ETX(1) ASCII : STX 01RPR10123.45 ETX HEX : 02h 30h 31h 52h 50h 52h 31h 30h 31h 32h 33h 2Eh 34h 35h 03h	15 Byte
SP3 (2-Stage)		
Transmit	Format : STX(1) ID(2) RPR2(4) ETX(1) ASCII : STX 01RPR2 ETX HEX : 02h 30h 31h 52h 50h 52h 32h 03h	8 Byte
Respond	Format : STX(1) ID(2) RPR2(4) SP3(7) ETX(1) ASCII : STX 01RPR20123.45 ETX HEX : 02h 30h 31h 52h 50h 52h 32h 30h 31h 32h 33h 2Eh 34h 35h 03h	15 Byte

SP4 (Free Fall)		
Transmit	Format : STX(1) ID(2) RFRE(4) ETX(1) ASCII : STX 01RFRE ETX HEX : 02h 30h 31h 52h 46h 52h 45h 03h	8 Byte
Respond	Format : STX(1) ID(2) RFRE(4) SP4(5) ETX(1) ASCII : STX 01RFRE0.123 ETX HEX : 02h 30h 31h 52h 46h 52h 45h 30h 2Eh 31h 32h 33h 03h	13 Byte
SP5 (Charge Free Fall)		
Transmit	Format : STX(1) ID(2) RHIG(4) ETX(1) ASCII : STX 01RHIG ETX HEX : 02h 30h 31h 52h 48h 49h 47h 03h	8 Byte
Respond	Format : STX(1) ID(2) RHIG(4) SP5(7) ETX(1) ASCII : STX 01RHIG0123.45 ETX HEX : 02h 30h 31h 52h 48h 49h 47h 30h 31h 32h 33h 2Eh 34h 35h 03h	15 Byte
SP6 (Discharge Free Fall)		
Transmit	Format : STX(1) ID(2) RLOW(4) ETX(1) ASCII : STX 01RLOW ETX HEX : 02h 30h 31h 52h 4Ch 4Fh 57h 03h	8 Byte
Respond	Format : STX(1) ID(2) RLOW(4) SP6(7) ETX(1) ASCII : STX 01RLOW0123.45 ETX HEX : 02h 30h 31h 52h 4Ch 4Fh 57h 30h 31h 32h 33h 2Eh 34h 35h 03h	15 Byte
Current Weight, External Input, Relay Out		
Transmit	Format : STX(1) ID(2) RWRS(4) ETX(1) ASCII : STX 01RWRS ETX HEX : 02h 30h 31h 52h 57h 52h 53h 03h	8 Byte
Respond	Format : STX(1) ID(2) RWRS(4) Mark(1) Current Weight(7) External Input 1~4(4) Relay Out 1~6(6) ETX(1) ASCII : STX 01RWRS0123.450000100000 ETX HEX : 02h 30h 31h 52h 57h 52h 53h 2Bh 30h 31h 32h 33h 2Eh 34h 35h 30h 30h 30h 30h 31h 30h 30h 30h 30h 30h 03h	26 Byte
Current Part Number		
Transmit	Format : STX(1) ID(2) RPNO(4) ETX(1) ASCII : STX 01RPNO ETX HEX : 02h 30h 31h 52h 50h 4Eh 4Fh 03h	8 Byte
Respond	Format : STX(1) ID(2) RPNO(4) Part Number(2) ETX(1) ASCII : STX 01RPNO01 ETX HEX : 02h 30h 31h 52h 50h 4Eh 4Fh 30h 31h 03h	10 Byte

SP1, SP2, SP3, SP4		
Transmit	Format : STX(1) ID(2) RFTT(4) ETX(1) ASCII : STX 01RFTT ETX HEX : 02h 30h 31h 52h 46h 54h 54h 03h	8 Byte
Respond	Format : STX(1) ID(2) RFTT(4) SP1(7) SP2(7) SP3(7) SP4(5) ETX(1) ASCII : STX 01RFTT010123.45123.450123.4501.23 ETX HEX : 02h 30h 31h 52h 46h 54h 54h 30h 31h 32h 33h 2Eh 34h 35h 30h 31h 32h 33h 2Eh 34h 35h 30h 31h 32h 33h 2Eh 34h 35h 30h 31h 2Eh 32h 33h 03h	34 Byte

### 7-3-2. Write command

-Transmit(normal): STX + ID(2Byte) + ACK + ETX

-Transmit(error): STX + ID(2Byte) + NAK + ETX

Zero Setting					
Transmit	Format : STX(1) ID(2) WZER(4) ETX(1) ASCII : STX 01WZER ETX HEX : 02h 30h 31h 57h 5Ah 45h 52h 03h				8 Byte
Respond	Normal	Format : STX(1) ID(2) ACK(1) ETX(1) ASCII : STX 01 ACK ETX HEX : 02h 30h 31h 06h 03h	Error	Format : STX(1) ID(2) NAK(1) ETX(1) ASCII : STX 01 NAK ETX HEX : 02h 30h 31h 15h 03h	5 Byte
Tare Setting					
Transmit	Format : STX(1) ID(2) WTAR(4) ETX(1) ASCII : STX 01WTAR ETX HEX : 02h 30h 31h 57h 54h 41h 52h 03h				8 Byte
Respond	Normal	Format : STX(1) ID(2) ACK(1) ETX(1) ASCII : STX 01 ACK ETX HEX : 02h 30h 31h 06h 03h	Error	Format : STX(1) ID(2) NAK(1) ETX(1) ASCII : STX 01 NAK ETX HEX : 02h 30h 31h 15h 03h	5 Byte
Tare Reset					
Transmit	Format : STX(1) ID(2) WTRS(4) ETX(1) ASCII : STX 01WTRS ETX HEX : 02h 30h 31h 57h 54h 52h 53h 03h				8 Byte
Respond	Normal	Format : STX(1) ID(2) ACK(1) ETX(1) ASCII : STX 01 ACK ETX HEX : 02h 30h 31h 06h 03h	Error	Format : STX(1) ID(2) NAK(1) ETX(1) ASCII : STX 01 NAK ETX HEX : 02h 30h 31h 15h 03h	5 Byte

Print					
Transmit	Format : STX(1) ID(2) WPRT(4) ETX(1) ASCII : STX 01WPRT ETX HEX : 02h 30h 31h 57h 50h 52h 54h 03h				8 Byte
Respond	Normal	Format : STX(1) ID(2) ACK(1) ETX(1) ASCII : STX 01 ACK ETX HEX : 02h 30h 31h 06h 03h	Error	Format : STX(1) ID(2) NAK(1) ETX(1) ASCII : STX 01 NAK ETX HEX : 02h 30h 31h 15h 03h	5 Byte
Print Sub-total					
Transmit	Format : STX(1) ID(2) WSPR(4) ETX(1) ASCII : STX 01WSPR ETX HEX : 02h 30h 31h 57h 53h 50h 52h 03h				8 Byte
Respond	Normal	Format : STX(1) ID(2) ACK(1) ETX(1) ASCII : STX 01 ACK ETX HEX : 02h 30h 31h 06h 03h	Error	Format : STX(1) ID(2) NAK(1) ETX(1) ASCII : STX 01 NAK ETX HEX : 02h 30h 31h 15h 03h	5 Byte
Delete Sub-total					
Transmit	Format : STX(1) ID(2) WSTC(4) ETX(1) ASCII : STX 01WSTC ETX HEX : 02h 30h 31h 57h 53h 54h 43h 03h				8 Byte
Respond	Normal	Format : STX(1) ID(2) ACK(1) ETX(1) ASCII : STX 01 ACK ETX HEX : 02h 30h 31h 06h 03h	Error	Format : STX(1) ID(2) NAK(1) ETX(1) ASCII : STX 01 NAK ETX HEX : 02h 30h 31h 15h 03h	5 Byte

Print Total					
Transmit	Format : STX(1) ID(2) WGPR(4) ETX(1) ASCII : STX 01WGPR ETX HEX : 02h 30h 31h 57h 47h 50h 52h 03h				8 Byte
Respond	Normal	Format : STX(1) ID(2) ACK(1) ETX(1) ASCII : STX 01 ACK ETX HEX : 02h 30h 31h 06h 03h	Error	Format : STX(1) ID(2) NAK(1) ETX(1) ASCII : STX 01 NAK ETX HEX : 02h 30h 31h 15h 03h	5 Byte
Delete Total					
Transmit	Format : STX(1) ID(2) WGTC(4) ETX(1) ASCII : STX 01WGTC ETX HEX : 02h 30h 31h 57h 47h 54h 43h 03h				8 Byte
Respond	Normal	Format : STX(1) ID(2) ACK(1) ETX(1) ASCII : STX 01 ACK ETX HEX : 02h 30h 31h 06h 03h	Error	Format : STX(1) ID(2) NAK(1) ETX(1) ASCII : STX 01 NAK ETX HEX : 02h 30h 31h 15h 03h	5 Byte
Time Setting					
Transmit	Format : STX(1) ID(2) WTIM(4) TIME(6) ETX(1) ASCII : STX 01WTIM123035 ETX HEX : 02h 30h 31h 57h 54h 49h 4Dh 31h 32h 33h 30h 33h 35h 03h				14 Byte
Respond	Normal	Format : STX(1) ID(2) ACK(1) ETX(1) ASCII : STX 01 ACK ETX HEX : 02h 30h 31h 06h 03h	Error	Format : STX(1) ID(2) NAK(1) ETX(1) ASCII : STX 01 NAK ETX HEX : 02h 30h 31h 15h 03h	5 Byte
SP1 Setting (Setting Value)					
Transmit	Format : STX(1) ID(2) WFIL(4) SP1(7) ETX(1) ASCII : STX 01WFIL0123.45 ETX HEX : 02h 30h 31h 57h 46h 49h 4Ch 30h 31h 32h 33h 2Eh 34h 35h 03h				15 Byte
Respond	Normal	Format : STX(1) ID(2) ACK(1) ETX(1) ASCII : STX 01 ACK ETX HEX : 02h 30h 31h 06h 03h	Error	Format : STX(1) ID(2) NAK(1) ETX(1) ASCII : STX 01 NAK ETX HEX : 02h 30h 31h 15h 03h	5 Byte

SP2 Setting (1-Stage)					
Transmit	Format : STX(1) ID(2) WPR1(4) SP2(7) ETX(1) ASCII : STX 01WPR10123.45 ETX HEX : 02h 30h 31h 57h 50h 52h 31h 30h 31h 32h 33h 2Eh 34h 35h 03h				15 Byte
Respond	Normal	Format : STX(1) ID(2) ACK(1) ETX(1) ASCII : STX 01 ACK ETX HEX : 02h 30h 31h 06h 03h	Error	Format : STX(1) ID(2) NAK(1) ETX(1) ASCII : STX 01 NAK ETX HEX : 02h 30h 31h 15h 03h	5 Byte
SP3 Setting (2-Stage)					
Transmit	Format : STX(1) ID(2) WPR2(4) SP3(7) ETX(1) ASCII : STX 01WPR20123.45 ETX HEX : 02h 30h 31h 57h 50h 52h 32h 30h 31h 32h 33h 2Eh 34h 35h 03h				15 Byte
Respond	Normal	Format : STX(1) ID(2) ACK(1) ETX(1) ASCII : STX 01 ACK ETX HEX : 02h 30h 31h 06h 03h	Error	Format : STX(1) ID(2) NAK(1) ETX(1) ASCII : STX 01 NAK ETX HEX : 02h 30h 31h 15h 03h	5 Byte
SP4 Setting (Free Fall)					
Transmit	Format : STX(1) ID(2) WFRE(4) SP4(5) ETX(1) ASCII : STX 01WFRE01.23 ETX HEX : 02h 30h 31h 57h 46h 52h 45h 30h 31h 2Eh 32h 33h 03h				13 Byte
Respond	Normal	Format : STX(1) ID(2) ACK(1) ETX(1) ASCII : STX 01 ACK ETX HEX : 02h 30h 31h 06h 03h	Error	Format : STX(1) ID(2) NAK(1) ETX(1) ASCII : STX 01 NAK ETX HEX : 02h 30h 31h 15h 03h	5 Byte
SP5 Setting (Charge Free Fall)					
Transmit	Format : STX(1) ID(2) WHIG(4) SP5(7) ETX(1) ASCII : STX 01WHIG0123.45 ETX HEX : 02h 30h 31h 57h 48h 49h 47h 30h 31h 32h 33h 2Eh 34h 35h 03h				15 Byte
Respond	Normal	Format : STX(1) ID(2) ACK(1) ETX(1) ASCII : STX 01 ACK ETX HEX : 02h 30h 31h 06h 03h	Error	Format : STX(1) ID(2) NAK(1) ETX(1) ASCII : STX 01 NAK ETX HEX : 02h 30h 31h 15h 03h	5 Byte



SP6 Setting (Discharge Free Fall)					
Transmit	Format : STX(1) ID(2) WLOW(4) SP6(7) ETX(1) ASCII : STX 01WLOW0123.45 ETX HEX : 02h 30h 31h 57h 4Ch 4Fh 57h 30h 31h 32h 33h 2Eh 34h 35h 03h				15 Byte
Respond	Normal	Format : STX(1) ID(2) ACK(1) ETX(1) ASCII : STX 01 ACK ETX HEX : 02h 30h 31h 06h 03h	Error	Format : STX(1) ID(2) NAK(1) ETX(1) ASCII : STX 01 NAK ETX HEX : 02h 30h 31h 15h 03h	5 Byte
Part Number Change					
Transmit	Format : STX(1) ID(2) WPNO(4) Part Number(2) ETX(1) ASCII : STX 01WPNO10 ETX HEX : 02h 30h 31h 57h 50h 4Eh 4Fh 31h 30h 03h				10 Byte
Respond	Normal	Format : STX(1) ID(2) ACK(1) ETX(1) ASCII : STX 01 ACK ETX HEX : 02h 30h 31h 06h 03h	.Error	Format : STX(1) ID(2) NAK(1) ETX(1) ASCII : STX 01 NAK ETX HEX : 02h 30h 31h 15h 03h	5 Byte
SP2, SP3, SP4, SP1					
Transmit	Format : STX(1) ID(2) WFTD (4) SP2(7) SP3(7) SP4(5) SP1(7) ETX(1) ASCII : STX 01WFTD0123.450123.4501.230123.45ETX HEX : 02h 30h 31h 57h 46h 54h 44h 30h 31h 32h 33h 2Eh 34h 35h 30h 31h 32h 33h 2Eh 34h 35h 30h 31h 2Eh 32h 33h 30h 31h 32h 33h 2Eh 34h 35h 03h				34 Byte
Respond	Normal	Format : STX(1) ID(2) ACK(1) ETX(1) ASCII : STX 01 ACK ETX HEX : 02h 30h 31h 06h 03h	Error	Format : STX(1) ID(2) NAK(1) ETX(1) ASCII : STX 01 NAK ETX HEX : 02h 30h 31h 15h 03h	5 Byte

※ **How to calculate CHECK SUM**

**Check sum is a remainder when Sum of HEX value of the data from STX to ETX and the value is into 100.**

**ex) The sum HEX value from STX to ETX(02,30,31,52,43,57,54,03) is 1A6h.**

**Then, divide 1A6h by 100h(1A6h/100h) and the remainder is A6h.**

**This value is converted to ASCII and transferred to 41(A) 36(6).**

**Command Judgement of Command mode judges and outputs 06h(ACK) and 15h(NAK), Error code between the data which starts with 02h(STX) and ends with 03h(ETX)**

## 7-4. Modbus

- RO : Read Only
- RW : Read Write
- Setting value for Each Part Number cannot be over Max Capacity  
ex) If you want to set 35.00kg, input 3500 (0xDAC)
- Input 6 digits to set Date and Time  
ex) Input 140101 (0x22345) for 2014 January 1st  
Input 155017 (0x25D89) for 3:50:17 pm
- Refer to Memory Register Table below for lamp, error, digital input, standard key, special key.
- Modbus Function Codes
  - '03' (0x03) : Read Holding Registers
  - '04' (0x04) : Read Input Registers
  - '06' (0x06) : Write Single Registers
  - '16' (0x10) : Write Multiple Registers
- CRC Check Method is CRC-16.

### 7-4-1. Data Address Map

Content	Address		Length	Feature
Decimal Point	193	0xC1	1	R
Current Weight	194	0xC2	2	R
Tare Weight	196	0xC4	2	R
Key Input Tare Weight	198	0xC6	2	R
Measured weight	202	0xCA	2	R
Decimal Point	206	0xCE	2	R
Current Weight	208	0xD0	2	R
Tare Weight	210	0xD2	2	R
Key Input Tare Weight	216	0xD8	2	R
Measured weight	218	0xDA	2	R
Total Weighing Count of Current P/N	220	0xDC	2	R
Total Weight of Current P/N	222	0xDE	2	R
Under Count of Current P/N	224	0xE0	1	R
Pass Count of Current P/N	225	0xE1	1	R
Over Count of Current P/N	226	0xE2	1	R
Error Count of Current P/N	227	0xE3	1	R
Total Count	228	0xE4	2	R

Content	Address		Length	Feature
Total Weight	230	0xE6	2	R
Weighing Count of P/N 1	234	0xEA	2	R
Cumulative Weight of P/N 1	236	0xEC	2	R
Total Weighing Count of P/N 1	238	0xEE	2	R
Total Weight of P/N 1	240	0xF0	2	R
Under Count of P/N 1	242	0xF2	1	R
Pass Count of P/N 1	243	0xF3	1	R
Over Count of P/N 1	244	0xF4	1	R
Error Count of P/N 1	245	0xF5	1	R
Weighing Count of P/N 2	246	0xF6	2	R
Cumulative Weight of P/N 2	248	0xF8	2	R
Total Weighing Count of P/N 2	250	0xFA	2	R
Total Weight of P/N 2	252	0xFC	2	R
Under Count of P/N 2	254	0xFE	1	R
Pass Count of P/N 2	255	0xFF	1	R
Over Count of P/N 2	256	0x100	1	R
Error Count of P/N 2	257	0x101	1	R
~				
Weighing Count of P/N 50	822	0x336	2	R
Cumulative Weight of P/N 50	824	0x338	2	R
Total Weighing Count of P/N 50	826	0x33A	2	R
Total Weight of P/N 50	828	0x33C	2	R
Under Count of P/N 50	830	0x33E	1	R
PASS Count of P/N 50	831	0x33F	1	R
Over Count of P/N 50	832	0x340	1	R
Error Count of P/N 50	833	0x341	1	R
Date	834	0x342	2	R / W
Time	836	0x344	2	R / W
Key	838	0x346	1	R / W
Relay Out	840	0x348	1	R / W
Current P/N	841	0x349	1	R / W
SP1 of Current P/N	842	0x34A	2	R / W
SP2 of Current P/N	844	0x34C	2	R / W

Content	Address		Length	Feature
SP3 of Current P/N	846	0x34E	2	R / W
SP4 of Current P/N	848	0x350	2	R / W
Over-value of Current P/N	850	0x352	2	R / W
Under-value of Current P/N	852	0x354	2	R / W
Charge Free Fall	854	0x356	2	R / W
Discharge Free Fall	856	0x358	2	R / W
SP1 of P/N 1	858	0x35A	2	R / W
SP2 of P/N 1	860	0x35C	2	R / W
SP3 of P/N 1	862	0x35E	2	R / W
SP4 of P/N 1	864	0x360	2	R / W
SP1 of P/N 2	866	0x362	2	R / W
SP2 of P/N 2	868	0x364	2	R / W
SP3 of P/N 2	870	0x366	2	R / W
SP4 of P/N 2	872	0x368	2	R / W
~				
SP1 of P/N 50	1250	0x4E2	2	R / W
SP2 of P/N 50	1252	0x4E4	2	R / W
SP3 of P/N 50	1254	0x4E6	2	R / W
SP4 of P/N 50	1256	0x4E8	2	R / W

#### 7-4-2. External Input Data Map

1bit	2bit	3bit	4bit	5bit	6bit	7bit	8bit
IN 1	IN 2	IN 3	IN 4	IN 5	IN 6		

#### 7-4-3. Lamp Data Map

1bit	2bit	3bit	4bit	5bit	6bit	7bit	8bit
Stable	Zero	Tare	Hold	TXD	RXD	RUN	OUT1
9bit	10bit	11bit	12bit	13bit	14bit	15bit	16bit
OUT2	OUT3	OUT4	OUT5	OUT6	OUT7		SD_CAD
17bit	18bit	19bit	20bit	21bit	22bit	23bit	24bit
Minus ‘-’	Unit‘PCS’	Unit‘k	Unit‘t’	Unit‘g’	Unit‘lb’	Unit‘oz	

#### 7-4-4. Key Data Map

0x01	0x02	0x03	0x04	0x05	0x06	0x07	0x08
Zero	Tare/ Tare reset	Hold/ Hold reset	Part Number	SP1	Stop	SP2	SP3
0x09	0x10	0x11	0x12	0x13	0x14	0x15	0x16
SP4	Print	Tare	Tare reset		Start/Stop		

#### 7-4-5. Relay Out

1bit	2bit	3bit	4bit	5bit	6bit	7bit	8bit
OUT1	OUT2	OUT3	OUT4	OUT5	OUT6	OUT7	

## 7-5. Print format

It can be connect the indicator to all kinds of Serial Interface printers, but recommend you to use SE7200, SE7300 (30 columns) since the print format is programmed and fixed with the models.

	Korean (F120-00)	English (F120-01)
Continuous F121-00	<pre> ===== 날 짜 :      2016-01-18 시 간 :      19:25:04 장비 품번  순번  종량 01  01      1    2000 kg 01  01      2    2000 kg 01  01      3    2000 kg ===== </pre>	<pre> ===== DATE :      2016-01-18 TIME :      19:32:31 ID  PART  SERIAL  WEIGHT 01  01      1    2000 kg 01  01      2    2000 kg 01  01      3    2000 kg ===== </pre>
Single F121-02	<pre> ===== 날 짜 :      2016-01-18 시 간 :      19:27:11 장비 품번  순번  종량 01  01      1    2000 kg ===== 날 짜 :      2016-01-18 시 간 :      19:27:17 장비 품번  순번  종량 01  01      2    2000 kg ===== </pre>	<pre> ===== DATE :      2016-01-18 TIME :      19:33:47 ID  PART  SERIAL  WEIGHT 01  01      1    2000 kg ===== DATE :      2016-01-18 TIME :      19:33:52 ID  PART  SERIAL  WEIGHT 01  01      2    2000 kg ===== </pre>
Sub-total	<pre> ===== 소계 날 짜 :      2016-01-18 시 간 :      19:28:19 장비번호 :      01 품 번 :      01 계량횟수 :      2 누계중량 :      4000 kg ===== </pre>	<pre> ===== SUB DATE :      2016-01-18 TIME :      19:34:26 ID No :      01 PART :      01 COUNT :      2 SUB WEIGHT :      4000 kg ===== </pre>
Sub-total(1)	<pre> ===== 소계(1) 날 짜 :      2016-01-18 시 간 :      19:29:07 장비번호 :      01 품 번 :      01 계량횟수 :      2 누계중량 :      4000 kg ===== </pre>	<pre> ===== SUB(1) DATE :      2016-01-18 TIME :      19:34:55 ID No :      01 PART :      01 COUNT :      2 SUB WEIGHT :      4000 kg ===== </pre>
Total	<pre> ===== 총계 날 짜 :      2016-01-18 시 간 :      19:30:58 장비번호 :      01 품번  순번  종량 1      2    4000 kg 50     1    2000 kg 총 품번 :      2 총계량횟수 :      3 총계중량 :      6000 kg ===== </pre>	<pre> ===== TOTAL DATE :      2016-01-18 TIME :      19:35:45 ID No :      01 PART  SERIAL  WEIGHT 1      2    4000 kg 50     1    2000 kg TOTAL PART :      2 TOTAL COUNT :      3 TOTAL WEIGHT :      6000 kg ===== </pre>

Date and Time will be printed when it is number first in spite of Continuous format setting.

## 8. Error & treatment

### 8-1. Error during Load Cell Installation

Error	Causing	Treatment	Remark
Weight is unstable	<ol style="list-style-type: none"> <li>1. Load cell broken</li> <li>2. Load cell isolation resistance error</li> <li>3. There is interruption on the weighing part</li> <li>4. Summing board broken</li> </ol>	<ol style="list-style-type: none"> <li>1. Measure input/output resistance of Load cell.</li> <li>2. Measure Load cell isolation resistance</li> <li>3. Change Summing Board</li> <li>4. Make sure that there is nothing on the scale part.</li> </ol>	<ol style="list-style-type: none"> <li>1. Input Resistance of “EXC+” and “EXC-“ is about <math>400\Omega \pm 30</math></li> <li>2. Output Resistance of “SIG+“ and “SIG-“ is about <math>350\Omega \pm 3.5</math></li> <li>3. Isolate Resistance is more than <math>100M\Omega</math></li> </ol>
Weight increases regularly or does not returns to Zero.	<ol style="list-style-type: none"> <li>1. Load cell error</li> <li>2. Load cell connection Error</li> </ol>	<ol style="list-style-type: none"> <li>1. Check load cell connection</li> <li>2. Measure resistance value of load cell</li> </ol>	
Weight value is Minus (-)	<ol style="list-style-type: none"> <li>1. Load cell Output wires (SIG+, SIG-) are switched</li> </ol>	<ol style="list-style-type: none"> <li>1. Check load cell connection</li> </ol>	
“UnPAss” displays	<ol style="list-style-type: none"> <li>1. Load cell broken or Indicator connection error</li> </ol>	<ol style="list-style-type: none"> <li>1. Check load cell</li> <li>2. Check load cell connection</li> </ol>	
	<ol style="list-style-type: none"> <li>1. Power has been supplied when the scale part is not empty.</li> </ol>	<ol style="list-style-type: none"> <li>1. Remove weight on the load cell</li> </ol>	
“OL” display (OverLoad)	<ol style="list-style-type: none"> <li>1. Load cell broken or Indicator connection Error</li> <li>2. Weight over Max Capacity</li> </ol>	<ol style="list-style-type: none"> <li>1. Check load cell</li> <li>2. Check load cell connection</li> <li>3. Remove overloaded weight</li> </ol>	

## 8-2. Error during Calibration

Display	Cause
Er-001	The value of (Max Capacity/Division) is over 20,000.
Er-004	Standard weight value is over than Max Capacity
Er-005	Standard weight value is less than 10% of Max Capacity
Er-006	A/D Converting value is over the Maximum.
Er-007	A/D Converting value is under the Minimum.
Er-009	There is continuous vibration on the weighing part during calibration.
Er-010	Under "F-function" model, set value is "N.A"
Er-011	Exceed Tare range
Er-012	Exceed Near Zero range



### 8-3. Error and Treatment

Following is weighing process error and the indicator cannot measure precise weight in these cases.

Display	Cause	Treatment
<p>“Ad-Err” or “OL”</p>	<p>1. Load cell broken 2. Load cell cable broken 3. Load cell connection Error 4. A/D Board Error 5. Analogue value over 1,040,000. ※ “-OVER-” displays as well if the current value is over the absolute value of Max Capacity. Ex) Max Capacity is “100” and current weight is uner “-100” : “-OVER-” shows up.</p>	<p>1. Check load cell input digital value on Test mode 1. If this value does not change, check load cell and connection condition first. 2. Check weight value error with another indicator. 3. Check A/D converting board error with another indicator. 4. Check Power cable 5. Check load cell terminal</p>
<p>“UnPAss”</p>	<p>1. Power has been supplied when the scale part is not empty.  ※ F101-00 : “UnPAss” displays when power has been supplied though there is load of 10% of Max Capacity on the scale part.  ※ F101-01 : Indicator saved previous zero value so it normally works with the load on the scale part not showing “UnPAss”.</p>	<p>1. Make sure that the weighing part is empty before turn on the power. 2. Set F101-01(Back-up) so that the indicator can remember first empty value.</p>
<p>“HALt”</p>	<p>“HALT” on the display or continuous beep – Hard ware error</p>	<p>Please contact the distributor or the Head Office.</p>

### Warranty Certification

This product passed strict quality test of SEWHACNM Co., LTD.  
 If there is a defect of manufacturing or abnormal detection within warranty period, please contact our agent or distributor with this Warranty Certification so that you can get the product repaired or replaced.

### Warranty Clause

1. The warranty period is one(1) year from your purchase date.
2. Warranty Exemption Clause
  - Warranty period expired
  - Mal-function caused by repairmen, modification, etc without any authorization of the Headquarter.
  - Mal-function caused by user's carelessness
  - Mal-function caused by distribution of non-authorized distributor or agent
  - Mal-function caused since user did not follow the precautions.
  - Mal-function or defection caused by Fore Majeur
  - Without presentation of this Warranty Certification
3. Other
  - Warranty Certification without authorized stamp is invalid.

Main office: SEWHACNM Co.,Ltd. #504, 302dong, 397, Seokcheon-ro, Ojeong-gu, Bucheon-si, Gyeonggi-do, Korea Tel : +82 32-624-0060 Fax : +82 32-624-0065 E-mail : sales@sewhacnm.co.kr Homepage : http://www.sewhacnm.co.kr Made in KOREA	<b>Product</b>	Digital Weighing Indicator
	<b>Model</b>	SI540
	<b>Serial No.</b>	
	<b>AUTHORIZED STAMP</b>	